

GENERAL INFORMATION

AC200+™

Acrylic Injection Adhesive Anchoring System and Post-Installed Reinforcing Bar Connections

PRODUCT DESCRIPTION

The AC200+ is a two-component, high strength adhesive anchoring system. The system includes injection adhesive in plastic cartridges, mixing nozzles, dispensing tools and hole cleaning equipment. The AC200+ is designed for bonding threaded rod and reinforcing bar hardware into drilled holes in concrete base materials and for post-installed reinforcing bar connections.

GENERAL APPLICATIONS AND USES

- Bonding threaded rod and reinforcing bar into hardened concrete
- Evaluated for installation and use in dry and wet concrete
- Fast curing system which can be installed in a wide range of base material temperatures
- Qualified for seismic (earthquake) and wind loading

FEATURES AND BENEFITS

- + Designed for use with threaded rod and reinforcing bar hardware elements
- + Evaluated and recognized for freeze/thaw performance
- + Versatile system which can be used in a wide range of embedments in low and high strength concrete
- + Cartridge design allows for multiple uses using extra mixing nozzles
- + Mixing nozzles proportion adhesive and provide simple delivery method into drilled holes
- + Evaluated and recognized for long term and short term loading (see performance tables)

APPROVALS AND LISTINGS

- International Code Council, Evaluation Service (ICC-ES) ESR-4027 for cracked and uncracked concrete
- Code Compliant with 2015 IBC, 2015 IRC, 2012 IBC, 2012 IRC, 2009 IBC, and 2009 IRC
- Tested in accordance with ACI 355.4, ASTM E 488, and ICC-ES AC308 for use in structural concrete (Design according to ACI 318-14, Chapter 17 and ACI 318-11/08 Appendix D)
- Evaluated and qualified by an accredited independent testing laboratory for recognition in cracked and uncracked concrete including seismic and wind loading
- Compliant with NSF/ANSI 61 for drinking water system components - health effects; minimum requirements for materials in contact with potable water and water treatment
- Conforms to requirements of ASTM C881 and AASHTO M235, Types I, II, IV and V, Grade 3, Class A
- Department of Transportation listings - see www.DEWALT.com or contact transportation agency

GUIDE SPECIFICATIONS

CSI Divisions: 03 16 00 - Concrete Anchors, and 05 05 19 Post-Installed Concrete Anchors. Adhesive anchoring system shall be AC200+ as supplied by DEWALT, Towson, MD. Anchors shall be installed in accordance with published instructions and requirements of the Authority Having Jurisdiction.



SECTION CONTENTS

General Information..... 1
 Strength Design (SD)..... 2
 Installation Instructions (Solid Base Materials)..... 14
 Installation Instructions (Post-Installed Rebar)..... 15
 Reference Installation Tables 16
 Ordering Information..... 17



PACKAGING

Coaxial Cartridge

- 10 fl. oz.

Dual (side-by-side) Cartridge

- 28 fl. oz.

STORAGE LIFE & CONDITIONS

Dual cartridge: Eighteen months
 Coaxial cartridge: Eighteen months
 In a dry, dark environment with temperature ranging from 41°F to 90°F (5°C to 32°C)

ANCHOR SIZE RANGE (TYPICAL)

- 3/8" to 1-1/4" diameter threaded rod
- No. 3 to No. 10 reinforcing bar (rebar)

SUITABLE BASE MATERIALS

- Normal-weight concrete
- Lightweight concrete

PERMISSIBLE INSTALLATION CONDITIONS (ADHESIVE)

- Dry concrete
- Water-saturated concrete (wet)

STRENGTH DESIGN (SD)

Installation Specifications for Threaded Rod and Reinforcing Bar¹

CODE LISTED
ICC-ES ESR-4027



Dimension/Property	Notation	Units	Nominal Anchor Size												
			3/8		1/2		5/8		3/4		7/8		1		1-1/4
Threaded Rod	-	-	-	-	-	-	-	-	-	-	-	-	-	-	-
Reinforcing Bar	-	-	-	#3	-	#4	-	#5	#6	#7	#8	#9	-	#10	-
Nominal anchor diameter	d_a	in. (mm)	0.375 (9.5)		0.500 (12.7)		0.625 (15.9)		0.750 (19.1)	0.875 (22.2)	1.000 (25.4)	1.125 (28.6)	1.250 (31.8)		
Nominal ANSI drill bit size	d_o [d_{bit}]	in.	7/16 ANSI	1/2 ANSI	9/16 ANSI	5/8 ANSI	11/16 ANSI	3/4 ANSI	7/8 ANSI	1 ANSI	1-1/8 ANSI	1-3/8 ANSI	1-3/8 ANSI	1-3/8 ANSI	1-1/2 ANSI
Minimum embedment	$h_{ef,min}$	in. (mm)	2-3/8 (60)		2-3/4 (70)		3-1/8 (79)		3-1/2 (89)	3-1/2 (89)	4 (102)	4-1/2 (114)	5 (127)		
Maximum embedment	$h_{ef,max}$	in. (mm)	7-1/2 (191)		10 (254)		12-1/2 (318)		15 (381)	17-1/2 (445)	20 (508)	22-1/2 (572)	25 (635)		
Minimum concrete member thickness	h_{min}	in. (mm)	hef + 1-1/4 (hef + 30)						hef + 2d _o						
Minimum spacing distance	s_{min}	in. (mm)	1-7/8 (48)		2-1/2 (62)		3 (76)	3-5/8 (92)	4-1/4 (108)	4-3/4 (121)	5-1/4 (133)	5-1/4 (133)	5-7/8 (149)		
Minimum edge distance (100% T_{max})	c_{min}	in. (mm)	1-5/8 (41)		1-3/4 (44)		2 (51)	2-3/8 (60)	2-1/2 (64)	2-3/4 (70)	3 (75)	3 (75)	3-1/4 (80)		
Maximum Torque ²	T_{max}	ft-lbs	15 ³		30		44	66	96	147	185	221			
Minimum edge distance, reduced ^{2,4,5} (45% T_{max})	$c_{min,red}$	in. (mm)	-		-		1-3/4 (44)	1-3/4 (44)	1-3/4 (44)	1-3/4 (44)	2-3/4 (70)	2-3/4 (70)			
Maximum Torque, reduced ²	$T_{max,red}$	ft-lbs	7 ³		14		20	30	43	66	83	99			

1. For use with the design provisions of ACI 318-14 Ch. 17 or ACI 318-11 Appendix D as applicable, ICC-ES AC308, Section 4.2 and ESR-4027
2. Torque may not be applied to the anchors until the full cure time of the adhesive has been achieved
3. For ASTM A36/F1554 Grade 36 carbon steel threaded rods, $T_{max} = 11$ ft.-lb, $T_{max,red} = 5$.
4. For installations at the reduced minimum edge distance, $c_{min,red}$, the maximum torque applied must be max torque reduced, $T_{max,red}$.
5. For installations at the reduced minimum edge distance, $c_{min,red}$, the minimum spacing, $s_{min} = 5 \times d_a$.

Detail of Steel Hardware Elements used with Injection Adhesive System

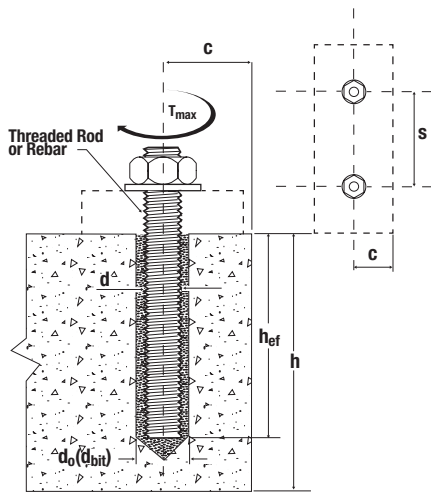

Threaded Rod and Deformed Reinforcing Bar Material Properties

Steel Description (General)	Steel Specification (ASTM)	Nominal Anchor Size (inch)	Minimum Ultimate Strength f_u (psi) (MPa)	Minimum Yield Strength f_y (psi) (MPa)
Carbon Rod	ASTM A36 or F1554, Grade 36	3/8 through 1-1/4	58,000 (400)	36,000 (250)
	ASTM F1554 Grade 55		75,000 (517)	55,000 (380)
	ASTM A193 Grade B7		125,000 (860)	105,000 (724)
	ASTM F1554 Grade 105		125,000 (860)	105,000 (724)
	ASTM A449	3/8 through 1	120,000 (828)	92,000 (635)
	ASTM A449	1-1/4	105,000 (720)	81,000 (560)
Stainless Rod (Alloy 304 / 316)	ASTM F593 CW1	3/8 through 5/8	100,000 (690)	65,000 (450)
	ASTM F593 CW2	3/4 through 1-1/4	85,000 (590)	45,000 (310)
	ASTM A193/A193M Grade B8/B8M2, Class 2B	3/8 through 1-1/4	95,000 (655)	75,000 (515)
Grade 60 Reinforcing Bar	ASTM A615, A767, A996 Grade 60	3/8 through 1-1/4 (#3 through #10)	90,000 (620)	60,000 (414)
	ASTM A706 Grade 60		80,000 (550)	60,000 (414)
Grade 40 Reinforcing Bar	ASTM A615 Grade 40	3/8 through 3/4 (#3 through #6)	60,000 (415)	40,000 (275)

**Steel Tension and Shear Design for Threaded Rod in Normal Weight Concrete
(For use with load combinations taken from ACI 318-14 Section 5.3)**

CODE LISTED
ICC-ES ESR-4027



Design Information		Symbol	Units	Nominal Rod Diameter ¹ (inch)						
				3/8	1/2	5/8	3/4	7/8	1	1-1/4
Threaded rod nominal outside diameter		d	inch (mm)	0.375 (9.5)	0.500 (12.7)	0.625 (15.9)	0.750 (19.1)	0.875 (22.2)	1.000 (25.4)	1.250 (31.8)
Threaded rod effective cross-sectional area		A _{se}	inch ² (mm ²)	0.0775 (50)	0.1419 (92)	0.2260 (146)	0.3345 (216)	0.4617 (298)	0.6057 (391)	0.9691 (625)
ASTM A 36 and ASTM F 1554 Grade 36	Nominal strength as governed by steel strength (for a single anchor)	N _{sa}	lbf (kN)	4,495 (20.0)	8,230 (36.6)	13,110 (58.3)	19,400 (86.3)	26,780 (119.1)	35,130 (156.3)	56,210 (250.0)
		V _{sa}	lbf (kN)	2,695 (12.0)	4,940 (22.0)	7,860 (35.0)	11,640 (51.8)	16,070 (71.4)	21,080 (93.8)	33,725 (150.0)
	Reduction factor for seismic shear	α _{V,seis}	-	0.60						
	Strength reduction factor for tension ²	φ	-	0.75						
		Strength reduction factor for shear ²	φ	0.65						
ASTM F 1554 Grade 55	Nominal strength as governed by steel strength (for a single anchor)	N _{sa}	lbf (kN)	5,810 (25.9)	10,640 (47.3)	16,950 (75.4)	25,085 (111.6)	34,625 (154.0)	45,425 (202.0)	72,680 (323.3)
		V _{sa}	lbf (kN)	3,485 (15.5)	6,385 (28.4)	10,170 (45.2)	15,050 (67.0)	20,775 (92.4)	27,255 (121.2)	43,610 (194.0)
	Reduction factor for seismic shear	α _{V,seis}	-	0.60						
	Strength reduction factor for tension ²	φ	-	0.75						
		Strength reduction factor for shear ²	φ	0.65						
ASTM A 193 Grade B7 and ASTM F 1554 Grade 105	Nominal strength as governed by steel strength (for a single anchor)	N _{sa}	lbf (kN)	9,685 (43.1)	17,735 (78.9)	28,250 (125.7)	41,810 (186.0)	57,710 (256.7)	75,710 (336.8)	121,135 (538.8)
		V _{sa}	lbf (kN)	5,815 (25.9)	10,640 (7.3)	16,950 (75.4)	25,085 (111.6)	34,625 (154.0)	45,425 (202.1)	72,680 (323.3)
	Reduction factor for seismic shear	α _{V,seis}	-	0.60						
	Strength reduction factor for tension ²	φ	-	0.75						
		Strength reduction factor for shear ²	φ	0.65						
ASTM A 449	Nominal strength as governed by steel strength (for a single anchor)	N _{sa}	lbf (kN)	9,300 (41.4)	17,025 (75.7)	27,120 (120.6)	40,140 (178.5)	55,905 (248.7)	72,685 (323.3)	101,755 (452.6)
		V _{sa}	lbf (kN)	5,580 (24.8)	10,215 (45.4)	16,270 (72.4)	24,085 (107.1)	33,540 (149.2)	43,610 (194.0)	61,050 (271.6)
	Reduction factor for seismic shear	α _{V,seis}	-	0.60						
	Strength reduction factor for tension ²	φ	-	0.75						
		Strength reduction factor for shear ²	φ	0.65						
ASTM F 568M Class 5.8	Nominal strength as governed by steel strength (for a single anchor)	N _{sa}	lbf (kN)	5,620 (25.0)	10,290 (45.8)	16,385 (72.9)	24,250 (107.9)	33,475 (148.9)	43,915 (195.4)	70,260 (312.5)
		V _{sa}	lbf (kN)	3,370 (15.0)	6,175 (27.5)	9,830 (43.7)	14,550 (64.7)	20,085 (89.3)	26,350 (117.2)	42,155 (187.5)
	Reduction factor for seismic shear	α _{V,seis}	-	0.60						
	Strength reduction factor for tension ²	φ	-	0.65						
		Strength reduction factor for shear ²	φ	0.60						
ASTM F 593 CW Stainless (Types 304 and 316)	Nominal strength as governed by steel strength (for a single anchor)	N _{sa}	lbf (kN)	7,750 (34.5)	14,190 (63.1)	22,600 (100.5)	28,430 (126.5)	39,245 (174.6)	51,485 (229.0)	82,370 (366.4)
		V _{sa}	lbf (kN)	4,650 (20.7)	8,515 (37.9)	13,560 (60.3)	17,060 (75.9)	23,545 (104.7)	30,890 (137.4)	49,425 (219.8)
	Reduction factor for seismic shear	α _{V,seis}	-	0.60						
	Strength reduction factor for tension ²	φ	-	0.65						
		Strength reduction factor for shear ²	φ	0.60						
ASTM A 193 Grade B8/ B8M2, Class 2B Stainless (Types 304 and 316)	Nominal strength as governed by steel strength (for a single anchor)	N _{sa}	lbf (kN)	7,365 (32.8)	13,480 (60.0)	21,470 (95.5)	31,775 (141.3)	43,860 (195.1)	57,545 (256.0)	92,065 (409.5)
		V _{sa}	lbf (kN)	4,420 (19.7)	8,085 (36.0)	12,880 (57.3)	19,065 (84.8)	26,315 (117.1)	34,525 (153.6)	55,240 (245.7)
	Reduction factor for seismic shear	α _{V,seis}	-	0.60						
	Strength reduction factor for tension ²	φ	-	0.75						
		Strength reduction factor for shear ²	φ	0.65						

For St: 1 inch = 25.4 mm, 1 lbf = 4.448 N. For pound-inch units: 1 mm = 0.03937 inches, 1 N = 0.2248 lbf.

1. Values provided for steel element material types are based on minimum specified strengths and calculated in accordance with ACI 318-14 Eq. 17.4.1.2 and Eq. 17.5.1.2b or ACI 318-11 Eq. (D-2) and Eq. (D-29), as applicable, except where noted. Nuts and washers must be appropriate for the rod. Nuts must have specified proof load stresses equal to or greater than the minimum tensile strength of the specified threaded rod.
2. The tabulated value of φ applies when the load combinations of Section 1605.2 of the IBC, ACI 318-14 5.3 or ACI 318-11 9.2, as applicable, are used in accordance with ACI 318-14 17.3.3 or ACI 318-11 D.4.3, as applicable. If the load combinations of ACI 318-11 Appendix C are used, the appropriate value of φ must be determined in accordance with ACI 318 D.4.4.

ADHESIVES

AC200+™
Acrylic Injection Adhesive Anchoring System

Steel Tension and Shear Design for Reinforcing Bars in Normal Weight Concrete
 (For use with load combinations taken from ACI 318-14 Section 5.3)

CODE LISTED
 ICC-ES ESR-4027



Design Information		Symbol	Units	Nominal Reinforcing Bar Size (Rebar)							
				No. 3	No. 4	No. 5	No. 6	No. 7	No. 8	No. 9	No. 10
Rebar nominal outside diameter		d	inch (mm)	0.375 (9.5)	0.500 (12.7)	0.625 (15.9)	0.750 (19.1)	0.875 (22.2)	1.000 (25.4)	1.125 (28.7)	1.250 (32.3)
Rebar effective cross-sectional area		A _{se}	inch ² (mm ²)	0.110 (71.0)	0.200 (129.0)	0.310 (200.0)	0.440 (283.9)	0.600 (387.1)	0.790 (509.7)	1.000 (645.2)	1.270 (819.4)
ASTM A615, A767, A996 Grade 60	Nominal strength as governed by steel strength (for a single anchor)	N _{sa}	lbf (kN)	9,900 (44.0)	18,000 (80.1)	27,900 (124.1)	39,600 (176.1)	54,000 (240.2)	71,100 (316.3)	90,000 (400.3)	114,300 (508.4)
		V _{sa}	lbf (kN)	5,940 (26.4)	10,800 (48.0)	16,740 (74.5)	23,760 (105.7)	32,400 (144.1)	42,660 (189.8)	54,000 (240.2)	68,580 (305.0)
	Reduction factor for seismic shear	α _{V,seis}	-	0.65							
	Strength reduction factor for tension ²	φ	-	0.65							
	Strength reduction factor for shear ²	φ	-	0.60							
ASTM A706 Grade 60	Nominal strength as governed by steel strength (for a single anchor)	N _{sa}	lbf (kN)	8,800 (39.1)	16,000 (71.2)	24,800 (110.3)	35,200 (156.6)	48,000 (213.5)	63,200 (281.1)	80,000 (355.9)	101,600 (452.0)
		V _{sa}	lbf (kN)	5,280 (23.5)	9,600 (42.7)	14,880 (66.2)	21,120 (94.0)	28,800 (128.1)	37,920 (168.7)	48,000 (213.5)	60,960 (271.2)
	Reduction factor for seismic shear	α _{V,seis}	-	0.65							
	Strength reduction factor for tension ²	φ	-	0.75							
	Strength reduction factor for shear ²	φ	-	0.65							
ASTM A 615 Grade 40	Nominal strength as governed by steel strength (for a single anchor)	N _{sa}	lbf (kN)	6,600 (29.4)	12,000 (53.4)	18,600 (82.7)	26,400 (117.4)	In accordance with ASTM A 615, Grade 40 bars are furnished only in sizes No. 3 through No. 6			
		V _{sa}	lbf (kN)	3,960 (17.6)	7,200 (32.0)	11,160 (49.6)	15,840 (70.5)				
	Reduction factor for seismic shear	α _{V,seis}	-	0.65							
	Strength reduction factor for tension ²	φ	-	0.65							
	Strength reduction factor for shear ²	φ	-	0.60							

For SI: 1 inch = 25.4 mm, 1 lbf = 4.448 N. For pound-inch units: 1 mm = 0.03937 inches, 1 N = 0.2248 lbf.

- Values provided for reinforcing bar material types based on minimum specified strengths and calculated in accordance with ACI 318-14 Eq. 17.4.1.2 and Eq. 17.5.1.2b or ACI 318-11 Eq. (D-2) and Eq. (D-29), as applicable.
- The tabulated value of φ applies when the load combinations of Section 1605.2 of the IBC, ACI 318-14 5.3 or ACI 318-11 9.2, as applicable, are used in accordance with ACI 318-14 17.3.3 or ACI 318-11 D.4.3, as applicable. If the load combinations of ACI 318-11 Appendix C are used, the appropriate value of φ must be determined in accordance with ACI 318 D.4.4.

FLOWCHART FOR THE ESTABLISHMENT OF DESIGN BOND STRENGTH

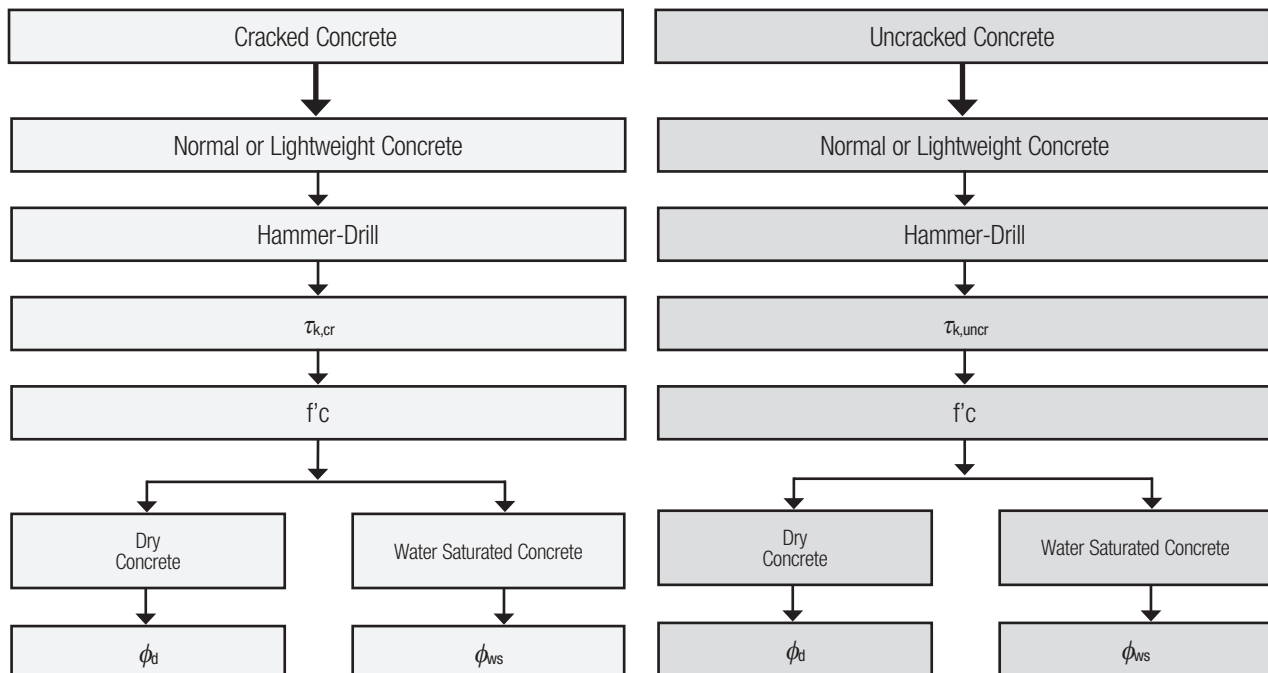

Concrete Breakout Design Information for Threaded Rod and in Holes Drilled with a Hammer Drill and Carbide Bit¹

CODE LISTED
ICC-ES ESR-4027



Design Information	Symbol	Units	Nominal Rod Diameter (inch)						
			3/8	1/2	5/8	3/4	7/8	1	1-1/4
Effectiveness factor for cracked concrete	$k_{c,cr}$	- (SI)	17 (7.1)						
Effectiveness factor for uncracked concrete	$k_{c,uncr}$	- (SI)	24 (10.0)						
Minimum embedment	$h_{ef,min}$	inch (mm)	2-3/8 (60)	2-3/4 (70)	3-1/8 (79)	3-1/2 (89)	3-1/2 (89)	4 (102)	5 (127)
Maximum embedment	$h_{ef,max}$	inch (mm)	7-1/2 (191)	10 (254)	12-1/2 (318)	15 (381)	17-1/2 (445)	20 (508)	25 (635)
Minimum anchor spacing	s_{min}	inch (mm)	1-7/8 (48)	2-1/2 (64)	3-1/8 (79)	3-5/8 (90)	4-1/8 (105)	4-3/4 (120)	5-7/8 (150)
Minimum edge distance ²	c_{min}	inch (mm)	1-5/8 (41)	1-3/4 (44)	2 (51)	2-3/8 (60)	2-1/2 (64)	2-3/4 (70)	3-1/4 (80)
Minimum edge distance, reduced ² (45% T_{max})	$c_{min,red}$	inch (mm)	-	-	1-3/4 (44)	1-3/4 (44)	1-3/4 (44)	1-3/4 (44)	2-3/4 (70)
Minimum member thickness	h_{min}	inch (mm)	$h_{ef} + 1-1/4$ ($h_{ef} + 30$)		$h_{ef} + 2d_o$ where d_o is hole diameter;				
Critical edge distance—splitting (for uncracked concrete only) ³	C_{ac}	inch	$C_{ac} = h_{ef} \cdot \left(\frac{\tau_{uncr}}{1160}\right)^{0.4} \cdot [3.1 - 0.7 \frac{h}{h_{ef}}]$						
		(mm)	$C_{ac} = h_{ef} \cdot \left(\frac{\tau_{uncr}}{8}\right)^{0.4} \cdot [3.1 - 0.7 \frac{h}{h_{ef}}]$						
Strength reduction factor for tension, concrete failure modes, Condition B ⁴	ϕ	-	0.65						
Strength reduction factor for shear, concrete failure modes, Condition B ⁴	ϕ	-	0.70						

For SI: 1 inch = 25.4 mm, 1 lbf = 4.448 N. For pound-inch units: 1 mm = 0.03937 inch, 1 N = 0.2248 lbf.

- Additional setting information is described in the installation instructions.
- For installation between the minimum edge distance, c_{min} , and the reduced minimum edge distance, $c_{min,red}$, the maximum torque applied must be reduced (multiplied) by a factor of 0.45.
- $\tau_{k,uncr}$ need not be taken as greater than: $\tau_{k,uncr} = k_{uncr} \cdot \sqrt{h_{ef} \cdot f'_c}$ and $\frac{h}{h_{ef}}$ need not be taken as larger than 2.4.
- Condition A requires supplemental reinforcement, while Condition B applies where supplemental reinforcement is not provided or where pryout governs, as set forth in ACI 318-14 17.3.3 or ACI 318-11 D.4.3, as applicable. The tabulated value of ϕ applies when the load combinations of Section 1605.2 of the IBC, ACI 318-14 5.3 or ACI 318-11 9.2, as applicable, are used in accordance with ACI 318-14 17.3.3 or ACI 318-11 D.4.3, as applicable. If the load combinations of ACI 318-11 Appendix C are used, the appropriate value of ϕ must be determined in accordance with ACI 318 D.4.4.

Bond Strength Design Information for Threaded Rod in Holes Drilled with a Hammer Drill and Carbide Bit¹

CODE LISTED
ICC-ES ESR-4027



Design Information	Symbol	Units	Nominal Rod Diameter (inch)							
			3/8	1/2	5/8	3/4	7/8	1	1-1/4	
Minimum embedment	$h_{ef,min}$	inch (mm)	2-3/8 (60)	2-3/4 (70)	3-1/8 (79)	3-1/2 (89)	3-1/2 (89)	4 (102)	5 (127)	
Maximum embedment	$h_{ef,max}$	inch (mm)	7-1/2 (191)	10 (254)	12-1/2 (318)	15 (381)	17-1/2 (445)	20 (508)	25 (635)	
Temperature Range A 122°F (50°C) Maximum Long-Term Service Temperature; 176°F (80°C) Maximum Short-Term Service Temperature ²	Characteristic bond strength in cracked concrete	$\tau_{k,cr}$	psi (N/mm ²)	1,041 (7.2)	1,041 (7.2)	1,111 (7.7)	1,219 (8.4)	1,212 (8.4)	1,206 (8.3)	1,146 (7.9)
	Characteristic bond strength in uncracked concrete	$\tau_{k,uncr}$	psi (N/mm ²)	2,601 (17.9)	2,415 (16.7)	2,262 (15.6)	2,142 (14.8)	2,054 (14.2)	2,000 (13.8)	1,990 (13.7)
Temperature Range B 161°F (72°C) Maximum Long-Term Service Temperature; 248°F (120°C) Maximum Short-Term Service Temperature ²	Characteristic bond strength in cracked concrete	$\tau_{k,cr}$	psi (N/mm ²)	905 (6.2)	906 (6.2)	966 (6.7)	1060 (7.3)	1054 (7.3)	1049 (7.2)	997 (6.9)
	Characteristic bond strength in uncracked concrete	$\tau_{k,uncr}$	psi (N/mm ²)	2,263 (15.6)	2,101 (14.5)	1,968 (13.6)	1,863 (12.8)	1,787 (12.3)	1,740 (12.0)	1732 (11.9)
Temperature Range C 212°F (100°C) Maximum Long-Term Service Temperature; 320°F (160°C) Maximum Short-Term Service Temperature ^{2,3}	Characteristic bond strength in cracked concrete	$\tau_{k,cr}$	psi (N/mm ²)	652 (4.5)	653 (4.5)	696 (4.8)	764 (5.3)	760 (5.2)	756 (5.2)	719 (5.0)
	Characteristic bond strength in uncracked concrete	$\tau_{k,uncr}$	psi (N/mm ²)	1631 (11.2)	1514 (10.4)	1418 (9.8)	1343 (9.3)	1288 (8.9)	1254 (8.6)	1248 (8.6)
Dry concrete	Anchor Category	-	-	1						
	Strength reduction factor	ϕ_s	-	0.65						
Water-saturated concrete	Anchor Category	-	-	2						
	Strength reduction factor	ϕ_{ws}	-	0.55						
Reduction factor for seismic tension ⁹	$\alpha_{N,seis}$	-	0.95							

For SI: 1 inch = 25.4 mm, 1 psi = 0.006894 MPa. For pound-inch units: 1 mm = 0.03937 inch, 1 MPa = 145.0 psi.

- Bond strength values correspond to a normal-weight concrete compressive strength $f'_c = 2,500$ psi (17.2 MPa). For concrete compressive strength, f'_c between 2,500 psi and 8,000 psi (17.2 MPa and 55.2 MPa), the tabulated characteristic bond strength may be increased by a factor of $(f'_c / 2,500)^{0.10}$ [For SI: $(f'_c / 17.2)^{0.10}$].
- Short-term elevated concrete base material service temperatures are those that occur over brief intervals, e.g. as a result of diurnal cycling. Long-term elevated concrete base material service temperatures are roughly constant over significant periods of time.
- Characteristic bond strengths are for sustained loads including dead and live loads. For load combinations consisting of short-term loads only, such as wind, bond strengths may be increased by 23 percent for the temperature range C.

Concrete Breakout Design Information for Reinforcing Bars in Holes Drilled with a Hammer Drill and Carbide Bit¹

CODE LISTED
ICC-ES ESR-4027



Design Information	Symbol	Units	Nominal Bar Size							
			#3	#4	#5	#6	#7	#8	#9	#10
Effectiveness factor for cracked concrete	$k_{c,cr}$	- (SI)	17 (7.1)							
Effectiveness factor for uncracked concrete	$k_{c,uncr}$	- (SI)	24 (10.0)							
Minimum embedment	$h_{ef,min}$	inch (mm)	2-3/8 (60)	2-3/4 (70)	3-1/8 (79)	3-1/2 (89)	3-1/2 (89)	4 (102)	4-1/2 (114)	5 (127)
Maximum embedment	$h_{ef,max}$	inch (mm)	7-1/2 (191)	10 (254)	12-1/2 (318)	15 (381)	17-1/2 (445)	20 (508)	22-1/2 (572)	25 (635)
Minimum anchor spacing	s_{min}	inch (mm)	1-7/8 (48)	2-1/2 (64)	3 (79)	3-5/8 (92)	4-1/4 (105)	4-3/4 (120)	5-1/4 (133)	5-7/8 (150)
Minimum edge distance ²	c_{min}	inch (mm)	1-5/8 (41)	1-3/4 (44)	2 (51)	2-3/8 (60)	2-1/2 (64)	2-3/4 (70)	3 (75)	3-1/4 (80)
Minimum edge distance, reduced ²	$c_{min,red}$	inch (mm)	-	-	1-3/4 (44)	1-3/4 (44)	1-3/4 (44)	1-3/4 (44)	2-3/4 (70)	2-3/4 (70)
Minimum member thickness	h_{min}	inch (mm)	$h_{ef} + 1-1/4 (h_{ef} + 30)$		$h_{ef} + 2d_o$ where d_o is hole diameter;					
Critical edge distance—splitting (for uncracked concrete only) ³	C_{ac}	inch	$C_{ac} = h_{ef} \cdot \left(\frac{\tau_{k,uncr}}{1160}\right)^{0.4} \cdot [3.1 - 0.7 \frac{h}{h_{ef}}]$							
		(mm)	$C_{ac} = h_{ef} \cdot \left(\frac{\tau_{k,uncr}}{8}\right)^{0.4} \cdot [3.1 - 0.7 \frac{h}{h_{ef}}]$							
Strength reduction factor for tension, concrete failure modes, Condition B ⁴	ϕ	-	0.65							
Strength reduction factor for shear, concrete failure modes, Condition B ⁴	ϕ	-	0.70							

For SI: 1 inch = 25.4 mm, 1 lbf = 4.448 N. For pound-inch units: 1 mm = 0.03937 inch, 1 N = 0.2248 lbf.

- Additional setting information is described in the installation instructions.
- For installation between the minimum edge distance, c_{min} , and the reduced minimum edge distance, $c_{min,red}$, the maximum torque applied must be reduced (multiplied) by a factor of 0.45.
- $\tau_{k,uncr}$ need not be taken as greater than: $\tau_{k,uncr} = k_{uncr} \cdot \sqrt{h_{ef}} \cdot f'_c$ and $\frac{h}{h_{ef}}$ need not be taken as larger than 2.4.
- Condition A requires supplemental reinforcement, while Condition B applies where supplemental reinforcement is not provided or where pryout governs, as set forth in ACI 318-14 17.3.3 or ACI 318-11 D.4.3, as applicable. The tabulated value of ϕ applies when the load combinations of Section 1605.2 of the IBC, ACI 318-14 5.3 or ACI 318-11 9.2, as applicable, are used in accordance with ACI 318-14 17.3.3 or ACI 318-11 D.4.3, as applicable. If the load combinations of ACI 318-11 Appendix C are used, the appropriate value of ϕ must be determined in accordance with ACI 318 D.4.4.

Bond Strength Design Information for Reinforcing Bars in Holes Drilled with a Hammer Drill and Carbide Bit¹

CODE LISTED
ICC-ES ESR-4027



Design Information	Symbol	Units	Nominal Bar Size								
			#3	#4	#5	#6	#7	#8	#9	#10	
Minimum embedment	$h_{ef,min}$	inch (mm)	2-3/8 (60.0)	2-3/4 (70.0)	3-1/8 (79.0)	3-1/2 (89.0)	3-1/2 (89.0)	4 (102.0)	4-1/2 (114.0)	5 (127.0)	
Maximum embedment	$h_{ef,max}$	inch (mm)	7-1/2 (191.0)	10 (254.0)	12-1/2 (318.0)	15 (381.0)	17-1/2 (445.0)	20 (508.0)	22-1/2 (572.0)	25 (635.0)	
Temperature Range A 122°F (50°C) Maximum Long-Term Service Temperature; 176°F (80°C) Maximum Short-Term Service Temperature ²	Characteristic bond strength in cracked concrete	$\tau_{k,cr}$	psi (N/mm ²)	1,088 (7.5)	1,053 (7.3)	1,128 (7.8)	1,169 (8.1)	1,174 (8.1)	1,156 (8.0)	1,141 (7.9)	1,164 (8.0)
	Characteristic bond strength in uncracked concrete	$\tau_{k,uncr}$	psi (N/mm ²)	2,200 (15.2)	2,101 (14.5)	2,028 (14.0)	1,969 (13.6)	1,921 (13.2)	1,881 (13.0)	1,846 (12.7)	1,815 (12.5)
Temperature Range B 161°F (72°C) Maximum Long-Term Service Temperature; 248°F (120°C) Maximum Short-Term Service Temperature ²	Characteristic bond strength in cracked concrete	$\tau_{k,cr}$	psi (N/mm ²)	947 (6.5)	916 (6.3)	982 (6.8)	1,017 (7.0)	1,021 (7.0)	1,006 (6.9)	993 (6.8)	1,012 (7.0)
	Characteristic bond strength in uncracked concrete	$\tau_{k,uncr}$	psi (N/mm ²)	1,914 (13.2)	1,828 (12.6)	1,764 (12.2)	1,713 (11.8)	1,672 (11.5)	1,636 (11.3)	1,616 (11.1)	1,579 (10.9)
Temperature Range C 212°F (100°C) Maximum Long-Term Service Temperature; 320°F (160°C) Maximum Short-Term Service Temperature ^{2,3}	Characteristic bond strength in cracked concrete	$\tau_{k,cr}$	psi (N/mm ²)	682 (4.7)	660 (4.6)	707 (4.9)	733 (5.1)	736 (5.1)	725 (5.0)	715 (4.9)	730 (5.0)
	Characteristic bond strength in uncracked concrete	$\tau_{k,uncr}$	psi (N/mm ²)	1,379 (9.5)	1,317 (9.1)	1,271 (8.8)	1,235 (8.5)	1,205 (8.3)	1,179 (8.1)	1,157 (8.0)	1,138 (7.8)
Dry concrete	Anchor Category	-	1								
	Strength reduction factor	ϕ_b	0.65								
Water-saturated concrete	Anchor Category	-	2								
	Strength reduction factor	ϕ_{ws}	0.55								
Reduction factor for seismic tension ³			$\alpha_{N,seis}$	0.95			1.00				

For SI: 1 inch = 25.4 mm, 1 psi = 0.006894 MPa. For pound-inch units: 1 mm = 0.03937 inch, 1 MPa = 145.0 psi.

- Bond strength values correspond to a normal-weight concrete compressive strength $f'_c = 2,500$ psi (17.2 MPa). For concrete compressive strength, f'_c between 2,500 psi and 8,000 psi (17.2 MPa and 55.2 MPa), the tabulated characteristic bond strength may be increased by a factor of $(f'_c / 2,500)^{0.10}$ [For SI: $(f'_c / 17.2)^{0.10}$].
- Short-term elevated concrete base material service temperatures are those that occur over brief intervals, e.g. as a result of diurnal cycling. Long-term elevated concrete base material service temperatures are roughly constant over significant periods of time.
- Characteristic bond strengths are for sustained loads including dead and live loads. For load combinations consisting of short-term loads only, such as wind, bond strengths may be increased by 23 percent for the temperature range C.



ADHESIVES

AC200+™
Acrylic Injection Adhesive Anchoring System

Tension and Shear Design Strength for Threaded Rod Installed in Uncracked Concrete (Bond or Concrete Strength)
Drilled with a Hammer-Drill and Carbide Bit in a Dry Hole Condition
Temperature Range A: 122°F (50°C) Maximum Long-Term Service Temperature;
176°F (80°C) Maximum Short-Term Service Temperature^{1,2,3,4,5,6,7,8,9}

Nominal Rod Size (in.)	Embed. Depth hef (in.)	Minimum Concrete Compressive Strength									
		f'c = 2,500 psi		f'c = 3,000 psi		f'c = 4,000 psi		f'c = 6,000 psi		f'c = 8,000 psi	
		ϕ_{Ncb} or ϕ_{Na} Tension (lbs.)	ϕ_{Vcb} or ϕ_{Vcp} Shear (lbs.)	ϕ_{Ncb} or ϕ_{Na} Tension (lbs.)	ϕ_{Vcb} or ϕ_{Vcp} Shear (lbs.)	ϕ_{Ncb} or ϕ_{Na} Tension (lbs.)	ϕ_{Vcb} or ϕ_{Vcp} Shear (lbs.)	ϕ_{Ncb} or ϕ_{Na} Tension (lbs.)	ϕ_{Vcb} or ϕ_{Vcp} Shear (lbs.)	ϕ_{Ncb} or ϕ_{Na} Tension (lbs.)	ϕ_{Vcb} or ϕ_{Vcp} Shear (lbs.)
3/8	2-3/8	2,855	2,570	3,125	2,920	3,610	3,575	4,425	4,745	5,105	5,500
	3	4,055	4,010	4,440	4,555	5,125	5,570	6,280	7,400	6,710	8,775
	4-1/2	7,445	7,935	8,155	9,015	9,395	11,015	9,785	13,710	10,070	16,015
	7-1/2	14,940	18,190	15,215	20,070	15,655	23,445	16,305	29,180	16,780	34,085
1/2	2-3/4	3,555	3,305	3,895	3,755	4,500	4,590	5,510	6,095	6,365	7,455
	4	6,240	6,700	6,835	7,610	7,895	9,310	9,665	12,365	11,080	15,080
	6	11,465	13,235	12,560	15,035	14,500	18,390	16,150	23,515	16,620	27,470
	10	24,660	31,215	25,110	34,445	25,845	40,235	26,915	50,085	27,700	58,500
5/8	3-1/8	4,310	4,120	4,720	4,680	5,450	5,720	6,675	7,600	7,710	9,295
	5	8,720	9,985	9,555	11,345	11,030	13,875	13,510	18,430	15,600	22,540
	7-1/2	16,020	19,725	17,550	22,410	20,265	27,410	23,635	35,695	24,325	41,695
	12-1/2	34,470	46,550	36,750	52,320	37,825	61,110	39,390	76,070	40,540	87,310
3/4	3-1/2	5,105	5,015	5,595	5,700	6,460	6,970	7,910	9,255	9,135	11,320
	6	11,465	13,595	12,560	15,445	14,500	18,895	17,760	25,095	20,505	30,695
	9	21,060	26,855	23,070	30,510	26,640	37,320	32,225	49,325	33,165	57,615
	15	45,315	63,370	49,640	72,000	51,575	84,420	53,710	105,080	55,280	119,060
7/8	3-1/2	5,105	4,930	5,595	5,605	6,460	6,855	7,910	9,100	9,135	11,130
	7	14,445	16,605	15,825	18,865	18,275	23,075	22,380	30,650	25,840	37,485
	10-1/2	26,540	32,800	29,070	37,265	33,570	45,580	41,115	60,540	43,290	71,360
	17-1/2	57,100	77,405	62,550	87,940	67,315	104,575	70,100	130,170	72,150	152,045
1	4	6,240	6,115	6,835	6,945	7,895	8,495	9,665	11,280	11,160	13,800
	8	17,650	19,750	19,335	22,435	22,325	27,440	27,340	36,450	31,570	44,580
	12	32,425	39,005	35,520	44,315	41,015	54,200	50,230	71,990	55,055	86,235
	20	69,765	92,055	76,425	104,585	85,610	126,375	89,155	157,310	91,755	183,745
1-1/4	5	8,720	8,170	9,555	9,285	11,030	11,355	13,510	15,085	15,600	18,450
	10	24,665	26,380	27,020	29,975	31,200	36,660	38,210	48,690	44,125	59,555
	15	45,315	52,110	49,640	59,200	57,320	72,410	70,200	96,175	81,060	117,630
	25	97,500	122,990	106,805	139,730	123,330	170,905	138,610	219,325	142,655	256,185

■ - Concrete Breakout Strength ■ - Bond Strength/Pryout Strength

- Tabular values are provided for illustration and are applicable for single anchors installed in uncracked normal-weight concrete with minimum slab thickness, $h_a = h_{min}$, and with the following conditions:
 - C_{a1} is greater than or equal to the critical edge distance, C_{ac}
 - C_{a2} is greater than or equal to 1.5 times C_{a1} .
- Calculations were performed according to ACI 318-14 Ch.17 and ICC-ES AC308. The load level corresponding to the failure mode listed [Concrete breakout strength, bond strength/pryout strength] must be checked against the tabulated steel strength of the corresponding threaded rod or rebar size and type, the lowest load level controls.
- Strength reduction factors (ϕ) for concrete breakout strength are based on ACI 318-14 Section 5.3 for load combinations. Condition B was assumed.
- Strength reduction factors (ϕ) for bond strength are determined from reliability testing and qualification in accordance with ICC-ES AC308 and are tabulated in this product information and in ESR-4027.
- Tabular values are permitted for static loads only, seismic loading is not considered with these tables. Periodic special inspection must be performed where required by code, see ESR-4027 for applicable information.
- For anchors subjected to tension resulting from sustained loading a supplemental check must be performed according to ACI 318-14 17.3.1.2.
- For designs that include combined tension and shear, the interaction of tension and shear loads must be calculated in accordance with ACI 318-14 Ch.17.
- Interpolation is not permitted to be used with the tabular values. For intermediate base material compressive strengths, please see ACI 318-14 Ch.17, ICC-ES AC308 and information included in this design supplement. For other design conditions including seismic considerations please see ACI 318-14 Ch.17 and ICC-ES AC308 and ESR-4027.
- Long term concrete temperatures are roughly constant over significant periods of time. Short-term elevated temperatures are those that occur over brief intervals, e.g. as a result of diurnal cycling.

Tension and Shear Design Strength in Threaded Rod Installed in Cracked Concrete (Bond or Concrete Strength)

Drilled with a Hammer-Drill and Carbide Bit in a Dry Hole Condition

Temperature Range A: 122°F (50°C) Maximum Long-Term Service Temperature;

176°F (80°C) Maximum Short-Term Service Temperature^{1,2,3,4,5,6,7,8,9}



Nominal Rod Size (in.)	Embed. Depth hef (in.)	Minimum Concrete Compressive Strength									
		f'c = 2,500 psi		f'c = 3,000 psi		f'c = 4,000 psi		f'c = 6,000 psi		f'c = 8,000 psi	
		ϕ_{tcb} or ϕ_{tca} Tension (lbs.)	ϕ_{scb} or ϕ_{sca} Shear (lbs.)	ϕ_{tcb} or ϕ_{tca} Tension (lbs.)	ϕ_{scb} or ϕ_{sca} Shear (lbs.)	ϕ_{tcb} or ϕ_{tca} Tension (lbs.)	ϕ_{scb} or ϕ_{sca} Shear (lbs.)	ϕ_{tcb} or ϕ_{tca} Tension (lbs.)	ϕ_{scb} or ϕ_{sca} Shear (lbs.)	ϕ_{tcb} or ϕ_{tca} Tension (lbs.)	ϕ_{scb} or ϕ_{sca} Shear (lbs.)
3/8	2-3/8	1,895	1,835	1,930	2,075	1,985	2,135	2,065	2,225	2,125	2,290
	3	2,390	2,865	2,435	3,255	2,505	3,980	2,610	5,285	2,685	5,785
	4-1/2	3,585	5,665	3,655	6,440	3,760	7,865	3,915	8,435	4,030	8,680
	7-1/2	5,980	12,875	6,090	13,115	6,265	13,495	6,525	14,055	6,715	14,465
1/2	2-3/4	2,520	2,360	2,760	2,680	3,065	3,280	3,190	4,355	3,285	5,325
	4	4,250	4,785	4,330	5,435	4,455	6,650	4,640	8,830	4,775	10,285
	6	6,375	9,455	6,495	10,740	6,685	13,135	6,960	14,990	7,165	15,430
	10	10,630	22,300	10,825	23,315	11,140	23,995	11,600	24,985	11,940	25,715
5/8	3-1/8	3,050	2,940	3,345	3,340	3,860	4,085	4,730	5,430	4,980	6,640
	5	6,175	7,135	6,765	8,105	7,430	9,910	7,740	13,165	7,965	16,100
	7-1/2	10,635	14,090	10,830	16,005	11,145	19,575	11,610	25,000	11,945	25,730
3/4	3-1/2	3,620	3,580	3,965	4,070	4,575	4,980	5,605	6,610	6,470	8,085
	6	8,120	9,710	8,895	11,035	10,270	13,495	12,225	17,925	12,585	21,925
	9	14,920	19,185	16,340	21,795	17,610	26,655	18,340	35,230	18,875	40,655
	15	28,005	45,265	28,520	51,425	29,350	60,300	30,565	65,835	31,460	67,755
7/8	3-1/2	3,620	3,525	3,965	4,000	4,575	4,895	5,605	6,500	6,470	7,950
	7	10,230	11,860	11,210	13,475	12,945	16,485	15,850	21,895	17,030	26,775
	10-1/2	18,800	23,430	20,590	26,620	23,780	32,555	24,820	43,240	25,545	50,970
	17-1/2	37,900	55,290	38,595	62,815	39,720	74,695	41,365	89,095	42,570	91,695
1	4	4,420	4,365	4,840	4,960	5,590	6,065	6,845	8,060	7,905	9,855
	8	12,500	14,105	13,695	16,025	15,815	19,600	19,365	26,035	22,130	31,845
	12	22,965	27,860	25,160	31,655	29,050	38,715	32,255	51,425	33,200	61,595
	20	49,255	65,755	50,160	74,705	51,625	90,270	53,760	112,365	55,330	119,170
1-1/4	5	6,175	5,835	6,765	6,630	7,815	8,110	9,570	10,775	11,050	13,175
	10	17,470	18,845	19,140	21,410	22,100	26,185	27,065	34,780	31,255	42,540
	15	32,095	37,220	35,160	42,285	40,600	51,720	47,895	68,695	49,290	84,020
	25	69,060	87,850	74,475	99,810	76,650	122,075	79,820	156,660	82,150	176,940

■ - Concrete Breakout Strength ■ - Bond Strength/Pryout Strength

- Tabular values are provided for illustration and are applicable for single anchors installed in cracked normal-weight concrete with minimum slab thickness, $h_a = h_{min}$, and with the following conditions:
 - c_{a1} is greater than or equal to the critical edge distance, c_{ac}
 - c_{a2} is greater than or equal to 1.5 times c_{a1} .
- Calculations were performed according to ACI 318-14 Ch.17 and ICC-ES AC308. The load level corresponding to the failure mode listed [Concrete breakout strength, bond strength/ pryout strength] must be checked against the tabulated steel strength of the corresponding threaded rod or rebar size and type, the lowest load level controls.
- Strength reduction factors (ϕ) for concrete breakout strength are based on ACI 318-14 Section 5.3 for load combinations. Condition B was assumed.
- Strength reduction factors (ϕ) for bond strength are determined from reliability testing and qualification in accordance with ICC-ES AC308 and are tabulated in this product information and in ESR-4027.
- Tabular values are permitted for static loads only, seismic loading is not considered with these tables. Periodic special inspection must be performed where required by code, see ESR-4027 for applicable information.
- For anchors subjected to tension resulting from sustained loading a supplemental check must be performed according to ACI 318-14 17.3.1.2.
- For designs that include combined tension and shear, the interaction of tension and shear loads must be calculated in accordance with ACI 318-14 Ch.17.
- Interpolation is not permitted to be used with the tabular values. For intermediate base material compressive strengths, please see ACI 318-14 Ch.17, ICC-ES AC308 and information included in this product supplement. For other design conditions including seismic considerations please see ACI 318-14 Ch.17 and ICC-ES AC308 and ESR-4027.
- Long term concrete temperatures are roughly constant over significant periods of time. Short-term elevated temperatures are those that occur over brief intervals, e.g. as a result of diurnal cycling.



ADHESIVES

AC200+™
Acrylic Injection Adhesive Anchoring System

Tension and Shear Design Strength for Reinforcing Bar Installed in Uncracked Concrete (Bond or Concrete Strength)
Drilled with a Hammer-Drill and Carbide Bit in a Dry Hole Condition
Temperature Range A: 122°F (50°C) Maximum Long-Term Service Temperature;
176°F (80°C) Maximum Short-Term Service Temperature^{1,2,3,4,5,6,7,8,9}

Nominal Rod Size (in.)	Embed. Depth hef (in.)	Minimum Concrete Compressive Strength									
		f'c = 2,500 psi		f'c = 3,000 psi		f'c = 4,000 psi		f'c = 6,000 psi		f'c = 8,000 psi	
		ϕ_{Ncb} or ϕ_{Na} Tension (lbs.)	ϕ_{Vcb} or ϕ_{Vcp} Shear (lbs.)	ϕ_{Ncb} or ϕ_{Na} Tension (lbs.)	ϕ_{Vcb} or ϕ_{Vcp} Shear (lbs.)	ϕ_{Ncb} or ϕ_{Na} Tension (lbs.)	ϕ_{Vcb} or ϕ_{Vcp} Shear (lbs.)	ϕ_{Ncb} or ϕ_{Na} Tension (lbs.)	ϕ_{Vcb} or ϕ_{Vcp} Shear (lbs.)	ϕ_{Ncb} or ϕ_{Na} Tension (lbs.)	ϕ_{Vcb} or ϕ_{Vcp} Shear (lbs.)
#3	2-3/8	2,855	2,570	3,125	2,920	3,610	3,575	4,365	4,705	4,495	4,840
	3	4,055	4,010	4,440	4,555	5,125	5,570	5,515	7,025	5,675	8,205
	4-1/2	7,445	7,935	7,720	8,820	7,945	10,300	8,275	12,820	8,515	14,975
	7-1/2	12,635	17,010	12,870	18,770	13,245	21,925	13,790	27,290	14,195	30,570
#4	2-3/4	3,555	3,305	3,895	3,755	4,500	4,590	5,510	6,095	6,365	7,455
	4	6,240	6,700	6,835	7,610	7,895	9,310	9,365	12,210	9,640	14,260
	6	11,465	13,235	12,560	15,035	13,490	17,870	14,050	22,240	14,460	25,980
	10	21,450	29,525	21,845	32,580	22,485	38,055	23,415	47,370	24,100	51,905
#5	3-1/8	4,310	4,120	4,720	4,680	5,450	5,725	6,675	7,600	7,710	9,295
	5	8,720	10,005	9,555	11,365	11,030	13,900	13,510	18,465	14,540	21,955
	7-1/2	16,020	19,760	17,550	22,450	20,265	27,460	21,190	34,235	21,805	39,985
	12-1/2	32,355	45,455	32,950	50,155	33,910	58,585	35,315	72,925	36,345	78,280
#6	3-1/2	5,105	5,015	5,595	5,700	6,460	6,970	7,910	9,255	9,135	11,320
	6	11,465	13,595	12,560	15,445	14,500	18,895	17,760	25,095	20,325	30,585
	9	21,060	26,855	23,070	30,510	26,640	37,320	29,625	47,690	30,490	55,705
	15	45,235	63,325	46,065	69,880	47,410	81,620	49,370	101,600	50,815	109,445
#7	3-1/2	5,105	4,930	5,595	5,605	6,460	6,855	7,910	9,100	9,135	11,130
	7	14,445	16,605	15,825	18,865	18,275	23,075	22,380	30,650	25,840	37,485
	10-1/2	26,540	32,800	29,070	37,265	33,570	45,580	39,340	59,480	40,485	69,475
	17-1/2	57,100	77,405	61,170	87,160	62,960	101,810	65,565	126,730	67,475	145,335
#8	4	6,240	6,115	6,835	6,945	7,895	8,495	9,665	11,280	11,160	13,800
	8	17,650	19,750	19,335	22,435	22,325	27,440	27,340	36,450	31,570	44,580
	12	32,425	39,005	35,520	44,315	41,015	54,200	50,230	71,990	51,780	84,145
	20	69,765	92,055	76,425	104,585	80,520	123,310	83,850	153,495	86,295	179,295
#9	4-1/2	7,445	7,110	8,155	8,080	9,420	9,880	11,535	13,125	13,320	16,055
	9	21,060	23,055	23,070	26,190	26,640	32,035	32,625	42,550	37,675	52,040
	13-1/2	38,690	45,540	42,380	51,740	48,940	63,280	59,940	84,050	64,315	99,830
	22-1/2	83,245	107,440	91,190	122,065	100,010	146,245	104,150	182,045	107,190	212,640
#10	5	8,720	8,160	9,555	9,270	11,030	11,335	13,510	15,060	15,600	18,420
	10	24,665	26,430	27,020	30,025	31,200	36,725	38,210	48,780	44,125	59,660
	15	45,315	52,205	49,640	59,310	57,320	72,545	70,200	96,350	78,065	116,085
	25	97,500	123,170	106,805	139,935	121,395	170,075	126,420	211,705	130,110	247,285

■ - Concrete Breakout Strength ■ - Bond Strength/Pryout Strength

- Tabular values are provided for illustration and are applicable for single anchors installed in uncracked normal-weight concrete with minimum slab thickness, $h_a = h_{min}$, and with the following conditions:
 - C_{at} is greater than or equal to the critical edge distance, C_{ac}
 - C_{a2} is greater than or equal to 1.5 times C_{at} .
- Calculations were performed according to ACI 318-14 Ch.17 and ICC-ES AC308. The load level corresponding to the failure mode listed [Concrete breakout strength, bond strength/pryout strength] must be checked against the tabulated steel strength of the corresponding threaded rod or rebar size and type, the lowest load level controls.
- Strength reduction factors (ϕ) for concrete breakout strength are based on ACI 318-14 Section 5.3 for load combinations. Condition B was assumed.
- Strength reduction factors (ϕ) for bond strength are determined from reliability testing and qualification in accordance with ICC-ES AC308 and are tabulated in this product information and in ESR-4027.
- Tabular values are permitted for static loads only, seismic loading is not considered with these tables. Periodic special inspection must be performed where required by code, see ESR-4027 for applicable information.
- For anchors subjected to tension resulting from sustained loading a supplemental check must be performed according to ACI 318-14 17.3.1.2.
- For designs that include combined tension and shear, the interaction of tension and shear loads must be calculated in accordance with ACI 318-14 Ch.17.
- Interpolation is not permitted to be used with the tabular values. For intermediate base material compressive strengths, please see ACI 318-14 Ch.17, ICC-ES AC308 and information included in this product supplement. For other design conditions including seismic considerations please see ACI 318-14 Ch.17 and ICC-ES AC308 and ESR-4027.
- Long term concrete temperatures are roughly constant over significant periods of time. Short-term elevated temperatures are those that occur over brief intervals, e.g. as a result of diurnal cycling.

Tension and Shear Design Strength for Reinforcing Bar Installed in Cracked Concrete (Bond or Concrete Strength)
Drilled with a Hammer-Drill and Carbide Bit in a Dry Hole Condition
Temperature Range A: 122°F (50°C) Maximum Long-Term Service Temperature;
176°F (80°C) Maximum Short-Term Service Temperature^{1,2,3,4,5,6,7,8,9}



Nominal Rod Size (in.)	Embed. Depth hef (in.)	Minimum Concrete Compressive Strength									
		f'c = 2,500 psi		f'c = 3,000 psi		f'c = 4,000 psi		f'c = 6,000 psi		f'c = 8,000 psi	
		ϕ_{Ncb} or ϕ_{Na} Tension (lbs.)	ϕ_{Vcb} or ϕ_{Vcp} Shear (lbs.)	ϕ_{Ncb} or ϕ_{Na} Tension (lbs.)	ϕ_{Vcb} or ϕ_{Vcp} Shear (lbs.)	ϕ_{Ncb} or ϕ_{Na} Tension (lbs.)	ϕ_{Vcb} or ϕ_{Vcp} Shear (lbs.)	ϕ_{Ncb} or ϕ_{Na} Tension (lbs.)	ϕ_{Vcb} or ϕ_{Vcp} Shear (lbs.)	ϕ_{Ncb} or ϕ_{Na} Tension (lbs.)	ϕ_{Vcb} or ϕ_{Vcp} Shear (lbs.)
#3	2-3/8	1,980	1,835	2,015	2,085	2,075	2,235	2,160	2,325	2,225	2,395
	3	2,500	2,865	2,545	3,255	2,620	3,980	2,730	5,020	2,810	5,860
	4-1/2	3,750	5,665	3,820	6,300	3,930	7,355	4,090	8,815	4,210	9,070
	7-1/2	6,250	12,150	6,365	13,405	6,550	14,105	6,820	14,690	7,020	15,120
#4	2-3/4	2,520	2,360	2,760	2,680	3,100	3,280	3,225	4,355	3,320	5,325
	4	4,300	4,785	4,380	5,435	4,505	6,650	4,695	8,720	4,830	10,185
	6	6,450	9,455	6,570	10,740	6,760	12,765	7,040	15,165	7,245	15,610
#5	3-1/8	3,050	2,940	3,345	3,340	3,860	4,090	4,730	5,430	5,055	6,640
	5	6,175	7,145	6,765	8,120	7,545	9,930	7,855	13,190	8,085	15,680
	7-1/2	10,795	14,115	10,995	16,035	11,315	19,615	11,785	24,455	12,130	26,125
#6	3-1/2	3,620	3,580	3,965	4,070	4,575	4,980	5,605	6,610	6,470	8,085
	6	8,120	9,710	8,895	11,035	10,270	13,495	11,725	17,925	12,065	21,845
	9	14,920	19,185	16,340	21,795	16,890	26,655	17,585	34,065	18,100	38,985
#7	3-1/2	3,620	3,525	3,965	4,000	4,575	4,895	5,605	6,500	6,470	7,950
	7	10,230	11,860	11,210	13,475	12,945	16,485	15,850	21,895	16,495	26,775
	10-1/2	18,800	23,430	20,590	26,620	23,085	32,555	24,040	42,485	24,745	49,625
#8	4	4,420	4,365	4,840	4,960	5,590	6,065	6,845	8,060	7,905	9,855
	8	12,500	14,105	13,695	16,025	15,815	19,600	19,365	26,035	21,215	31,845
	12	22,965	27,860	25,160	31,655	29,050	38,715	30,920	51,425	31,820	60,105
	20	47,210	65,755	48,080	74,705	49,485	88,080	51,530	109,640	53,035	114,230
#9	4-1/2	5,275	5,080	5,780	5,770	6,670	7,060	8,170	9,375	9,435	11,465
	9	14,920	16,465	16,340	18,710	18,870	22,880	23,110	30,390	26,500	37,170
	13-1/2	27,405	32,530	30,020	36,955	34,665	45,200	38,625	60,035	39,750	71,305
	22-1/2	58,965	76,740	60,060	87,190	61,815	104,460	64,375	130,030	66,250	142,695
#10	5	6,175	5,830	6,765	6,620	7,815	8,100	9,570	10,755	11,050	13,155
	10	17,470	18,880	19,140	21,445	22,100	26,230	27,065	34,840	31,255	42,615
	15	32,095	37,290	35,160	42,365	40,600	51,815	48,645	68,825	50,065	82,920
	25	69,060	87,980	75,645	99,955	77,855	121,485	81,075	151,220	83,440	176,635

■ - Concrete Breakout Strength ■ - Bond Strength/Pryout Strength

- Tabular values are provided for illustration and are applicable for single anchors installed in cracked normal-weight concrete with minimum slab thickness, $h_a = h_{min}$, and with the following conditions:
 - c_{a1} is greater than or equal to the critical edge distance, c_{ac}
 - c_{a2} is greater than or equal to 1.5 times c_{a1} .
- Calculations were performed according to ACI 318-14 Ch.17 and ICC-ES AC308. The load level corresponding to the failure mode listed [Concrete breakout strength, bond strength/pryout strength] must be checked against the tabulated steel strength of the corresponding threaded rod or rebar size and type, the lowest load level controls.
- Strength reduction factors (ϕ) for concrete breakout strength are based on ACI 318-14 Section 5.3 for load combinations. Condition B was assumed.
- Strength reduction factors (ϕ) for bond strength are determined from reliability testing and qualification in accordance with ICC-ES AC308 and are tabulated in this product information and in ESR-4027.
- Tabular values are permitted for static loads only, seismic loading is not considered with these tables. Periodic special inspection must be performed where required by code, see ESR-4027 for applicable information.
- For anchors subjected to tension resulting from sustained loading a supplemental check must be performed according to ACI 318-14 17.3.1.2.
- For designs that include combined tension and shear, the interaction of tension and shear loads must be calculated in accordance with ACI 318-14 Ch.17.
- Interpolation is not permitted to be used with the tabular values. For intermediate base material compressive strengths, please see ACI 318-14 Ch.17, ICC-ES AC308 and information included in this product supplement. For other design conditions including seismic considerations please see ACI 318-14 Ch.17 and ICC-ES AC308 and ESR-4027.
- Long term concrete temperatures are roughly constant over significant periods of time. Short-term elevated temperatures are those that occur over brief intervals, e.g. as a result of diurnal cycling.



Tension Design of Steel Elements (Steel Strength)^{1,2}

Steel Elements - Threaded Rod and Reinforcing Bar										
Nominal Rod/Rebar Size (in. or No.)	ASTM A36 and ASTM F1554 Grade 36	ASTM F1554 Grade 55	ASTM A193 Grade B7 and ASTM F1554 Grade 105	ASTM A449	ASTM F568M Class 5.8	ASTM F593 CW Stainless (Types 304 and 316)	ASTM A193 Grade B8/ B8M2, Class 2B Stainless (Types 304 and 316)	ASTM A615 Grade 60 Rebar	ASTM A706 Grade 60 Rebar	ASTM A615 Grade 40 Rebar
	ϕN_{sa} Tension (lbs.)	ϕN_{sa} Tension (lbs.)	ϕN_{sa} Tension (lbs.)	ϕN_{sa} Tension (lbs.)	ϕN_{sa} Tension (lbs.)	ϕN_{sa} Tension (lbs.)	ϕN_{sa} Tension (lbs.)	ϕN_{sa} Tension (lbs.)	ϕN_{sa} Tension (lbs.)	ϕN_{sa} Tension (lbs.)
3/8 or #3	3,370	4,360	7,265	6,975	3,655	5,040	5,525	6,435	6,600	4,290
1/2 or #4	6,175	7,980	13,300	12,770	6,690	9,225	10,110	11,700	12,000	7,800
5/8 or #5	9,835	12,715	21,190	20,340	10,650	14,690	16,105	18,135	18,600	12,090
3/4 or #6	14,550	18,815	31,360	30,105	15,765	18,480	23,830	25,740	26,400	17,160
7/8 or #7	20,085	25,970	43,285	41,930	21,760	25,510	32,895	35,100	36,000	-
1 or #8	26,350	34,070	56,785	54,515	28,545	33,465	43,160	46,215	47,400	-
#9	-	-	-	-	-	-	-	58,500	60,000	-
1-1/4 or #10	42,160	54,510	90,850	76,315	45,670	53,540	69,050	74,295	76,200	-

■ - Steel Strength

1. Steel tensile design strength according to ACI 318-14 Ch.17, $\phi N_{sa} = \phi \cdot A_{se,N} \cdot f_{uta}$
2. The tabulated steel design strength in tension must be checked against the bond strength/concrete capacity design strength to determine the controlling failure mode, the lowest load level controls.

Shear Design of Steel Elements (Steel Strength)^{1,2}

Steel Elements - Threaded Rod and Reinforcing Bar										
Nominal Rod/Rebar Size (in. or No.)	ASTM A36 and ASTM F1554 Grade 36	ASTM F1554 Grade 55	ASTM A193 Grade B7 and ASTM F1554 Grade 105	ASTM A449	ASTM F568M Class 5.8	ASTM F593 CW Stainless (Types 304 and 316)	ASTM A193 Grade B8/ B8M2, Class 2B Stainless (Types 304 and 316)	ASTM A615 Grade 60 Rebar	ASTM A706 Grade 60 Rebar	ASTM A615 Grade 40 Rebar
	ϕV_{sa} Shear (lbs.)	ϕV_{sa} Shear (lbs.)	ϕV_{sa} Shear (lbs.)	ϕV_{sa} Shear (lbs.)	ϕV_{sa} Shear (lbs.)	ϕV_{sa} Shear (lbs.)	ϕV_{sa} Shear (lbs.)	ϕV_{sa} Shear (lbs.)	ϕV_{sa} Shear (lbs.)	ϕV_{sa} Shear (lbs.)
3/8 or #3	1,755	2,265	3,775	3,625	2,020	2,790	2,870	3,565	3,430	2,375
1/2 or #4	3,210	4,150	6,915	6,640	3,705	5,110	5,255	6,480	6,240	4,320
5/8 or #5	5,115	6,610	11,020	10,575	5,900	8,135	8,375	10,045	9,670	6,695
3/4 or #6	7,565	9,785	16,305	15,655	8,730	10,235	12,390	14,255	13,730	9,505
7/8 or #7	10,445	13,505	22,505	21,805	12,050	14,130	17,105	19,440	18,720	-
1 or #8	13,700	17,715	29,525	28,345	15,810	18,535	22,445	25,595	24,650	-
#9	-	-	-	-	-	-	-	32,400	31,200	-
1-1/4 or #10	21,920	28,345	47,250	39,685	25,295	29,655	35,905	41,150	39,625	-

■ - Steel Strength

1. Steel shear design strength according to ACI 318-14 Ch.17, $\phi V_{sa} = \phi \cdot 0.60 \cdot A_{se,V} \cdot f_{uta}$
2. The tabulated steel design strength in shear must be checked against the bond strength/concrete capacity design strength to determine the controlling failure mode, the lowest load level controls.

Development Lengths for Common Reinforcing Bar Connections^{1,2,3,6}

Design Information	Symbol	Reference Standard	Units	Nominal Rebar Size (US)							
				#3	#4	#5	#6	#7	#8	#9	#10
Nominal rebar diameter	d_b	ASTM A615/A706, Grade 60 ($f_y = 60$ ksi)	in. (mm)	0.375 (9.5)	0.5 (12.7)	0.625 (15.9)	0.75 (19.1)	0.875 (22.2)	1 (25.4)	1.128 (28.6)	1.27 (32.3)
Nominal rebar area	A_b		in ² (mm ²)	0.11 (71)	0.2 (127)	0.31 (198)	0.44 (285)	0.6 (388)	0.79 (507)	1 (645)	1.27 (817)
Development length in $f'_c = 2,500$ psi concrete ^{4,5}	l_d	ACI 318-14 25.4.2.3 or ACI 318-11 12.2.3 as applicable	in. (mm)	12 (305)	14.4 (366)	18 (457)	21.6 (549)	31.5 (800)	36 (914)	40.6 (1031)	45.7 (1161)
Development length in $f'_c = 3,000$ psi concrete ^{4,5}			in. (mm)	12 (305)	13.1 (334)	16.4 (417)	19.7 (501)	28.8 (730)	32.9 (835)	37.1 (942)	41.7 (1060)
Development length in $f'_c = 4,000$ psi concrete ^{4,5}			in. (mm)	12 (305)	12 (305)	14.2 (361)	17.1 (434)	24.9 (633)	28.5 (723)	32.1 (815)	36.2 (920)
Development length in $f'_c = 6,000$ psi concrete ^{4,5}			in. (mm)	12 (305)	12 (305)	12 (305)	13.9 (354)	20.3 (516)	23.2 (590)	26.2 (666)	29.5 (750)
Development length in $f'_c = 8,000$ psi concrete ^{4,5}			in. (mm)	12 (305)	12 (305)	12 (305)	12.1 (307)	17.6 (443)	20.1 (511)	22.7 (577)	25.6 (649)

- For SI: 1 inch = 25.4 mm, 1 lbf = 4.448 N, 1 psi = 0.006897 MPa; for pound-inch units: 1 mm = 0.03937 inches, 1 N = 0.2248 lbf, 1 MPa = 145.0 psi.
- Calculated development lengths in accordance with ACI 318-14 25.4.2.3 or ACI 318-11 12.2.3, as applicable, for reinforcing bars are valid for static, wind, and earthquake loads.
 - Calculated development lengths in SDC C through F must comply with ACI 318-14 Chapter 18 or ACI 318-11 Chapter 21, as applicable.
 - For Class B splices, minimum length of lap for tension lap splices is $1.3l_d$ in accordance with ACI 318-14 25.5.2 and ACI 318-11 12.15.1, as applicable.
 - For lightweight concrete, $\lambda = 0.75$; therefore multiply development lengths by 1.33 (increase development length by 33 percent), unless the provisions of ACI 318-14 25.4.2.4 or ACI 318-11 12.2.4 (d), as applicable, are met to permit alternate values of λ (e.g. for sand-lightweight concrete, $\lambda = 0.85$; therefore multiply development lengths by 1.18). Refer to ACI 318-14 19.2.4 or ACI 318-11 8.6.1, as applicable.
 - $(\frac{C_b + K_{tr}}{d_b}) = 2.5$, $\psi_t = 1.0$, $\psi_s = 1.0$, $\psi_e = 0.8$ for $d_b \leq \#6$, 1.0 for $d_b > \#6$. Refer to ACI 318-14 25.4.2.4 or ACI 318-11 12.2.4, as applicable.
 - Calculations may be performed for other steel grades and concrete compressive strengths per ACI 318-14 Chapter 25 or ACI 318-11 Chapter 12, as applicable.

Installation Parameters for Common Post-Installed Reinforcing Bar Connections

Parameter	Symbol	Units	Nominal Rebar Size (US)							
			#3	#4	#5	#6	#7	#8	#9	#10
Nominal hole diameter ¹	d_o	in.	7/16	5/8	3/4	7/8	1	1 1/8	1-3/8	1-1/2
Effective embedment	h_{ef}	in.	2-3/8 to 7-1/2	2-3/4 to 10	3-1/8 to 12-1/2	3-1/2 to 15	3-1/2 to 17-1/2	4 to 20	4-1/2 to 22-1/2	5 to 25
Nominal hole diameter ¹	d_o	in.	1/2	5/8	3/4	1	1-1/8	1-1/4	1-3/8	1-1/2
Effective embedment	h_{ef}	in.	7-1/2 to 22-1/2	10 to 30	12-1/2 to 37-1/2	15 to 45	17-1/2 to 52-1/2	20 to 60	22-1/2 to 67-1/2	25 to 75

- For SI: 1 inch = 25.4 mm,; for pound-inch units: 1 mm = 0.03937 inches.
- For any case, it must be possible for the reinforcing bar (rebar) to be inserted into the cleaned hole without resistance.
 - Consideration should be given regarding the commercial availability of carbide drill bits (including hollow drill bits), as applicable, with lengths necessary to achieve effective embedments for post-installed reinforcing bar connections.

Installation Detail for Post-Installed Reinforcing Bar Connection

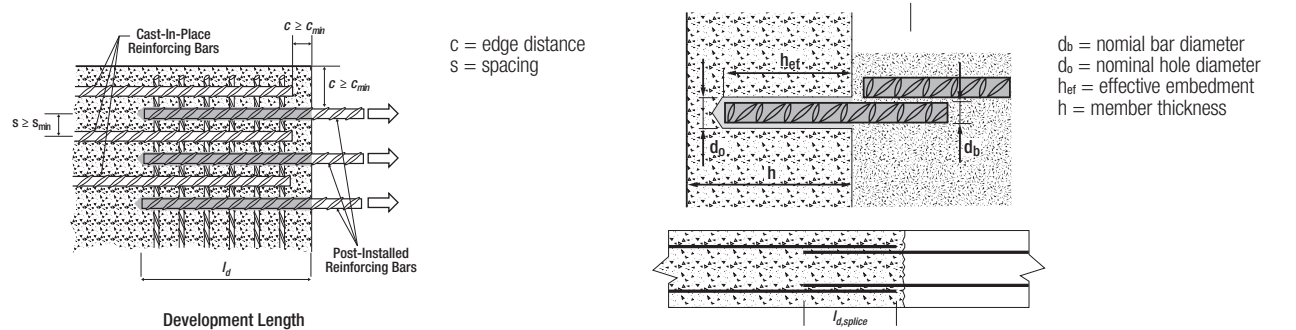

Examples of Development Length Application Details for Post-Installed Reinforcing Bar Connections Provided for Illustrator

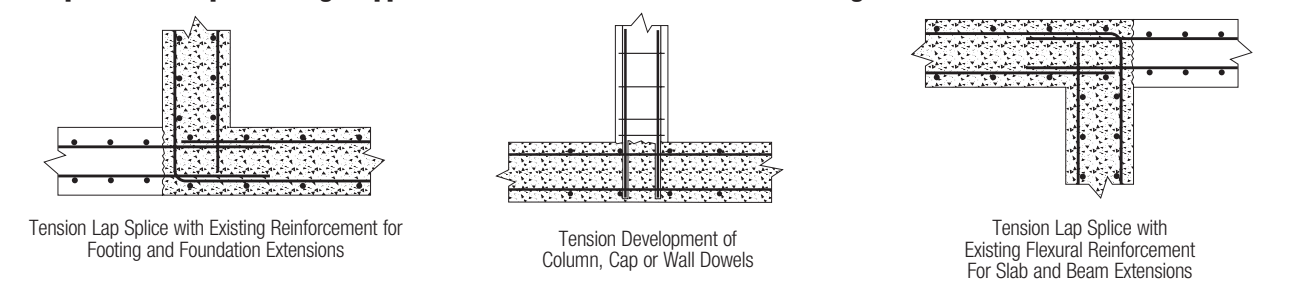

Hole Cleaning Tools and Accessories for Post-Installed Rebar Connections^{1,2,3,4,5,6,7}

Rebar Size (No.)	Drill Bit Size (inch)	Brush Size (inch)	Brush Length (inches)	Wire Brush (Cat. No.)	Plug Size (inch)	Piston Plug (Cat. No.)
3	7/16	7/16	6-3/4	PFC1671050	N/A	N/A
	1/2	1/2	6-3/4	PFC1671010	N/A	N/A
4	5/8	5/8	6-3/4	PFC1671200	N/A	N/A
5	3/4	3/4	7-7/8	PFC1671250	3/4	PFC1691520
6	7/8	7/8	7-7/8	PFC1671300	7/8	PFC1691530
	1	1	11-7/8	PFC1671350	1	PFC1691540
7	1	1	11-7/8	PFC1671350	1	PFC1691540
	1-1/8	1-1/8	11-7/8	PFC1671400	1-1/8	PFC1691550
8	1-1/8	1-1/8	11-7/8	PFC1671425	1-1/8	PFC1691550
	1-1/4	1-1/4	11-7/8	PFC1671450	1-1/4	PFC1691555
9	1-3/8	1-3/8	11-7/8	PFC1671450	1-3/8	PFC1691560
10	1-1/2	1-1/2	11-7/8	PFC1671500	1-1/2	PFC1691570

1. If the DEWALT DustX+ extraction system is used to automatically clean the holes during drilling, standard hole cleaning (brushing and blowing following drilling) is not required.
2. Holes may be drilled with hammer-drill, i.e. rotary impact drills or rock drills with a carbide drill bit (including hollow bits).
3. For any case, it must be possible for the reinforcing bar to be inserted into the cleaned drill hole without resistance.
4. A brush extension (Cat.#08282) must be used with a steel wire brush for holes drilled deeper than the listed brush length.
5. Brush adaptors for power tool connections are available for drill chuck (Cat.#08296) and SDS (Cat.#08283).
6. A flexible extension tube (Cat.#08297) or flexible extension hose (Cat.#PFC1640600) or equivalent approved by DEWALT must be used if the bottom or back of the anchor hole is not reached with the mixing nozzle only.
7. All overhead (i.e upwardly inclined) installations require the use of piston plugs during where one is tabulated together with the anchor size (see table). N/A = Not applicable. All horizontal installations require the use of piston plugs where one is tabulated together with the anchor size and where the embedment depth is greater than 8 inches. A flexible extension tube (Cat.#08297) or flexible extension hose (Cat.#PFC1640600) or equivalent approved by DEWALT must be used with piston plugs.



Wire Brush



Brush Extension



Drill Chuck Adapter



SDS Adapter



Premium Piston Plug



Compressed Air Nozzle



DustX+™ System

INSTALLATION INSTRUCTIONS (SOLID BASE MATERIALS)

DRILLING

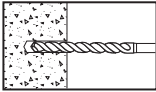

1- Drill a hole into the base material with rotary hammer drill (i.e. percussion drill) and a carbide drill bit to the size and embedment required by the selected steel hardware element (reference installation specifications for threaded rod and reinforcing bar). The tolerances of the carbide drill bits, including hollow bits, must meet ANSI Standard B212.15.

- Precaution: Use suitable eye and skin protection. Avoid inhalation of dust during drilling and/or removal.

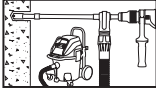

- **Note!** In case of standing water in the drilled hole (flooded hole condition), all the water has to be removed from the hole (e.g. vacuum, compressed air, etc.) prior to cleaning.

Drilling in dry base material is recommended when using hollow drill bits (vacuum must be on).

GO TO STEP 3 FOR HOLES DRILLED WITH DUSTX+™ EXTRACTION SYSTEM (NO FURTHER HOLE CLEANING IS REQUIRED). OTHERWISE GO TO STEP 2A FOR HOLE CLEANING INSTRUCTIONS.

HOLE CLEANING DRY OR WET/WATER-SATURATED HOLES (BLOW 2X, BRUSH 2X, BLOW 2X)

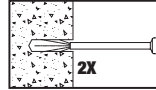

2a- Starting from the bottom or back of the anchor hole, blow the hole clean with compressed air (min. 90 psi / 6 bar) a minimum of two times (2x). If the back of the drilled hole is not reached an extension shall be used.

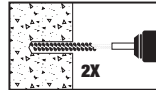

2b- Determine brush diameter (see hole cleaning equipment selection table) for the drilled hole and brush the hole by hand or attach the brush with adaptor to a rotary drill tool or battery screw gun. Brush the hole with the selected wire brush a minimum of two times (2x). A brush extension (supplied by DEWALT) must be used for drill hole depth > 6" (150mm). The wire brush diameter must be checked periodically during use. The wire brush diameter must be checked periodically during use. The brush should resist insertion into the drilled hole, if not, the brush is too small and must be replaced with proper brush diameter (i.e. new wire brush).

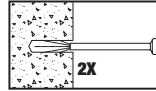

2c- Finally blow the hole clean again with compressed air (min. 90 psi / 6 bar) a minimum of two times (2x). If the back of the drilled hole is not reached an extension shall be used. When finished the hole should be clean and free of dust, debris, ice, grease, oil or other foreign material.

PREPARING



3- Check adhesive expiration date on cartridge label. Do not use expired product. Review Safety Data Sheet (SDS) before use. Cartridge temperature must be between 41°F - 104°F (5°C - 40°C) when in use. Review published working and cure times. Consideration should be given to the reduced gel (working) time of the adhesive in warm temperatures. For permitted range of the base material temperature, see published gel and curing times.

- Attach a supplied mixing nozzle to the cartridge. Unless otherwise noted do not modify the mixer in any way and make sure the mixing element is inside the nozzle. Load the cartridge into the correct dispensing tool.
- **Note:** Always use a new mixing nozzle with new cartridge of adhesive and also for all work interruptions exceeding the published gel (working) time of the adhesive.

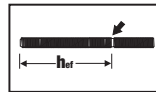

4- Prior to inserting the anchor rod or rebar into the filled drilled hole, the position of the embedment depth has to be marked on the anchor. Verify anchor element is straight and free of surface damage.



5- Adhesives must be properly mixed to achieve published properties. For new cartridges and nozzles, prior to dispensing adhesive into the drilled hole, separately dispense at least three full strokes of adhesive through the mixing nozzle until the adhesive is a consistent **GRAY** color.

- Review and note the published working and cure times (reference gel time and curing time table) prior to injection of the mixed adhesive into the cleaned anchor hole.

INSTALLATION

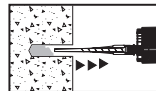

6- Fill the cleaned hole approximately two-thirds full with mixed adhesive starting from the bottom or back of the anchor hole. Slowly withdraw the mixing nozzle as the hole fills to avoid creating air pockets or voids. A plastic extension tube (Cat# 08281 or 08297) or equivalent approved by DEWALT must be used with the mixing nozzle if the bottom or back of the anchor hole is not reached with the mixing nozzle (see reference tables for installation).



WITH PISTON PLUG:

Note! Piston plugs (see hole cleaning equipment selection table) must be used with and attached to the mixing nozzle and extension tube for:

- Overhead installations and installations between horizontal and overhead in concrete with anchor rod 5/8" to 1-1/4" diameter and rebar size #5 to #10
- All installations with drill hole depth > 10" (250mm) with anchor rod 5/8" to 1-1/4" diameter and rebar sizes #5 to #10

Insert piston plug to the back of the drilled hole and inject as described in the method above. During installation the piston plug will be naturally extruded from the drilled hole by the adhesive pressure.

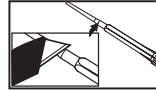

In the case that flexible tubing is used (Cat. #PFC1640600), the mixing nozzle may be trimmed at the preformation on the front port before attachment of the tubing. Verify the mixing element is inside the nozzle before use.

Attention! Do not install anchors overhead or upwardly inclined without installation hardware supplied by DEWALT and also receiving proper training and/or certification. Contact DEWALT for details prior to use.

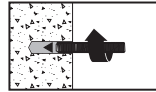

7- The anchor should be free of dirt, grease, oil or other foreign material. Push clean threaded rod or reinforcing bar into the anchor hole while turning slightly to ensure positive distribution of the adhesive until the embedment depth is reached. Observe the gel (working) time.

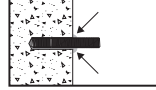

8- Ensure that the anchor element is installed to the specific embedment depth. Adhesive must completely fill the annular gap at the concrete surface. Following installation of the anchor element, remove excess adhesive. Protect the anchor element threads from fouling with adhesive. For all installations the anchor element must be restrained from movement throughout the specified curing period (as necessary) through the use of temporary wedges, external supports, or other methods. Minor adjustment to the position of the anchor element may be performed during the gel (working) time only.

CURING AND LOADING

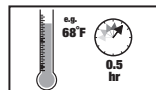

9- Allow the adhesive anchor to cure to the specified full curing time prior to applying any load (reference gel time and curing time table).

- Do not disturb, torque or load the anchor until it is fully cured.

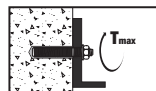

10- After full curing of the adhesive anchor, a fixture can be installed to the anchor and tightened up to the maximum torque (reference installation specifications for threaded rod and reinforcing bar table) by using a calibrated torque wrench.

- Take care not to exceed the maximum torque for the selected anchor.

INSTALLATION INSTRUCTIONS (POST-INSTALLED REBAR)

HAMMER DRILLING

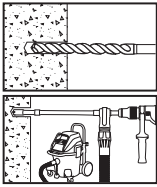

- 1- Drill a hole into the base material with rotary hammer drill (i.e. percussion drill) and a carbide drill bit to the size and embedment required by the selected steel hardware element (reference installation specifications for threaded rod and reinforcing bar). The tolerances of the carbide drill bits, including hollow bits, must meet ANSI Standard B212.15.
 - Precaution: Use suitable eye and skin protection. Avoid inhalation of dust during drilling and/or removal.
 - **Note!** In case of standing water in the drilled hole (flooded hole condition), all the water has to be removed from the hole (e.g. vacuum, compressed air, etc.) prior to cleaning.
- Drilling in dry base materials is recommended when using hollow drill bits (vacuum must be on).

GO TO STEP 3 FOR HOLES DRILLED WITH DUSTX+™ EXTRACTION SYSTEM (NO FURTHER HOLE CLEANING IS REQUIRED). OTHERWISE GO TO STEP 2A FOR HOLE CLEANING INSTRUCTIONS.

HOLE CLEANING DRY OR WET HOLES (BLOW 2X, BRUSH 2X, BLOW 2X)

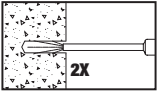

- 2a- Starting from the bottom or back of the drilled hole, blow the hole clean a minimum of two times (2x). Use a compressed air nozzle (min. 90 psi) for all sizes of reinforcing bar (rebar).

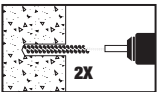

- 2b- Determine brush diameter (see hole cleaning accessories for post-installed rebar selection table) for the drilled hole and brush the hole by hand or attach the brush with adaptor to a rotary drill tool or battery screw gun. Brush the hole with the selected wire brush a minimum of two times (2x). A brush extension (supplied by DEWALT) must be used for drill hole depth > 6" (150mm). The wire brush diameter must be checked periodically during use. The brush should resist insertion into the drilled hole, if not, the brush is too small and must be replaced with proper brush diameter (i.e. new wire brush).

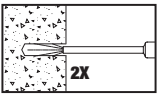

- 2c- **Repeat Step 2a** again by blowing the hole clean a minimum of two times (2x). When finished the hole should be clean and free of dust, debris, oil or other foreign material.

PREPARING



- 3- Check adhesive expiration date on cartridge label. Do not use expired product. Review Safety Data Sheet (SDS) before use. Review published gel (working) and cure times. Cartridge adhesive temperature must be between 41°F - 104°F (5°C - 40°C) when in use.

Note: Consideration should be given to the reduced gel (working) time of the adhesive in warm temperatures. For the permitted range of the base material temperature see published gel and cure times.

Attach a supplied mixing nozzle to the cartridge. Unless otherwise noted do not modify the mixer in any way and make sure the mixing element is inside the nozzle. Load the cartridge into the correct dispensing tool.

- Note: Always use a new mixing nozzle with new cartridge of adhesive and also for all work interruptions exceeding the published gel (working) time of the adhesive.

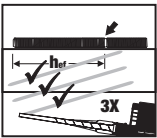

- 4- Prior to inserting the rebar into the filled drilled hole, the position of the embedment depth has to be marked on the anchor. Verify anchor element is straight and free of surface damage.

- 5- Adhesive must be properly mixed to achieve published properties. Prior to dispensing adhesive into the drilled hole, separately dispense at least three full strokes of adhesive through the mixing nozzle until the adhesive is a consistent **GRAY** color.

Review and note the published gel (working) and cure times prior to injection of the mixed adhesive into the cleaned anchor hole.

INSTALLATION

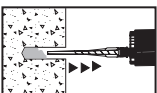

- 6- Fill the cleaned hole approximately two-thirds full with mixed adhesive starting from the bottom or back of the anchor hole. Slowly withdraw the mixing nozzle as the hole fills to avoid creating air pockets or voids. A flexible extension tube (Cat.# 08297) or flexible extension hose (Cat.# PFC1640600) or equivalent approved by DEWALT must be used with the mixing nozzle if the bottom or back of the anchor hole is not reached with the mixing nozzle (see reference tables for installation). (see hole cleaning tools and accessories for post-installed rebar table).

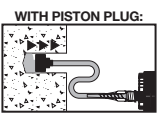

Note! Piston plugs must be used with and attached to mixing nozzle and extension tube for overhead (i.e. upwardly inclined) installations and horizontal installations with rebar sizes as indicated in the hole cleaning tools and accessories for post-installed rebar table. Insert piston plug to the back of the drilled hole and inject as described in the method above. During injection of the adhesive the piston plug will be naturally extruded from the drilled hole by the adhesive pressure.

- In the case that flexible tubing is used (Cat. #PFC1640600), the mixing nozzle may be trimmed at the preformation on the front port before attachment of the tubing. Verify the mixing element is inside the nozzle before use.

Attention! Do not install anchors overhead or upwardly inclined without installation hardware supplied by DEWALT and also receiving proper training and/or certification. Contact DEWALT for details prior to use.



- 7- The reinforcing bar should be free of dirt, grease, oil or other foreign material. Push clean rebar into the anchor hole while turning slightly to ensure positive distribution of the adhesive until the embedment depth is reached. Observe the gel (working) time.

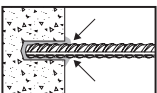

- 8- Ensure that the anchor element is installed to the specific embedment depth. Adhesive must completely fill the annular gap at the concrete surface. Following installation of the anchor element, remove excess adhesive. Protect the anchor element threads from fouling with adhesive. For all installations the anchor element must be restrained from movement throughout the specified curing period (as necessary) through the use of temporary wedges, external supports, or other methods. Minor adjustment to the position of the anchor element may be performed during the gel (working) time only.

CURING AND LOADING

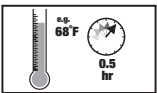

- 9- Allow the adhesive anchor to cure to the specified full curing time prior to applying any load (reference gel time and curing time table).

- Do not disturb, torque or load the anchor until it is fully cured.

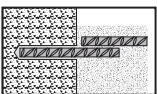

- 10- After full curing of the rebar connection, new concrete can be poured (placed) to the installed rebar connection.

REFERENCE INSTALLATION TABLES

Gel (working) Time and Curing Table

Temperature of base material	Gel (working) time	Full curing time
23°F (-5°C) to 31°F (-1°C)	50 minutes	5 hours
32°F (0°C) to 40°F (4°C)	25 minutes	3.5 hours
41°F (5°C) to 49°F (9°C)	15 minutes	2 hours
50°F (10°C) to 58°F (14°C)	10 minutes	1 hour
59°F (15°C) to 67°F (19°C)	6 minutes	40 minutes
68°F (20°C) to 85°F (29°C)	3 minutes	30 minutes
86°F (30°C) to 104°F (40°C)	2 minutes	30 minutes

Linear interpolation for intermediate base material temperature is possible.
Cartridge temperature must be between 41°F (5°C) and 104°F (40°C) when in use.

Hole Cleaning Equipment Selection Table for AC200+

Rod Diameter (inch)	Rebar Size (No.)	ANSI Drill Bit Diameter (inch)	Brush Length (inches)	Steel Wire Brush ^{1,2} (Cat. #)	Blowout Tool	Number of cleaning actions
Solid Base Material						
3/8	-	7/16	5-3/8	PFC1671050	Compressed air nozzle only, Cat #8292 (min. 90 psi)	2x blowing 2x brushing 2x blowing
-	#3	1/2	5-3/8	PFC1671100		
1/2	-	9/16	5-3/8	PFC1671150		
-	#4	5/8	5-3/8	PFC1671200		
5/8	-	11/16	5-3/8	PFC1671225		
-	#5	3/4	5-3/8	PFC1671250		
3/4	#6	7/8	5-3/8	PFC1671300		
7/8	#7	1	5-3/8	PFC1671350		
1	#8	1-1/8	5-3/8	PFC1671400		
1-1/4	#9	1-3/8	5-3/8	PFC1671450		
-	#10	1-1/2	5-3/8	PFC1671500		

1. For any case, it must be possible for the steel anchor element to be inserted into the cleaned drill hole without resistance.
2. An SDS-plus adaptor (Cat. #PFC1671830) is required to attach a steel wire brush to the drill tool. For hand brushing, attach manual brush wood handle (Cat. #PFC1671000) to the steel brush.
3. A brush extension (Cat. #PFC1671820) must be used with a steel wire brush for holes drilled deeper than the listed brush length.

Piston Plugs for Adhesive Anchors^{1,2,3}

Plug Size (inch)	ANSI Drill Bit Diameter (inch)	Piston Plug (Cat. #)	Piston Plug
Solid Base Materials			
11/16	11/16	08258	
3/4	3/4	08259	
7/8	7/8	08300	
1	1	08301	
1-1/8	1-1/8	08303	
1-1/4	1-1/4	08307	
1-3/8	1-3/8	08305	
1-1/2	1-1/2	08309	

1. All overhead or upwardly inclined installations require the use of piston plugs where one is tabulated together with the anchor size.
2. All installations require the use of piston plugs where one is tabulated together with the anchor size and where the embedment depth is greater than 10 inches.
3. A flexible plastic extension tube (Cat. #08281 or #08297) or equivalent approved by DEWALT must be used with piston plugs.

PERMISSIBLE INSTALLATION CONDITIONS (ADHESIVE)

Dry Concrete: cured concrete that, at the time of adhesive anchor installation, has not been exposed to water for the preceding 14 days.
Water-Saturated Concrete (wet): cured concrete that, at the time of adhesive anchor installation, has been exposed to water over a sufficient length of time to have the maximum possible amount of absorbed water into the concrete pore structure to a depth equal to the anchor embedment depth.

ORDERING INFORMATION

ADHESIVES

AC200+ Cartridges

Cat. No.	Description	Std. Box	Std. Ctn.	Pallet
PFC1271050	AC200+ 10 fl. oz. Quik-Shot	12	36	648
PFC1271150	AC200+ 28 fl. oz. Dual cartridge	-	8	240

One AC200+ mixing nozzle is packaged with each cartridge.
AC200+ mixing nozzles must be used to ensure complete and proper mixing of the adhesive.



Cartridge System Mixing Nozzles

Cat. No.	Description	Std. Pkg.	Std. Ctn.
PFC1641600	Mixing nozzle (with 8" extension)	2	24
08281	Mixing nozzle extension, 8" long	2	24
08297	Mixing nozzle extension, 20" long	1	12



Dispensing Tools for Injection Adhesive

Cat. No.	Description	Std. Box	Std. Ctn.
08437	Manual caulking gun for Quik-Shot	1	12
08479	High performance caulking gun for Quik-Shot	1	12
DCE560D1	10 fl. oz. cordless 20v battery powered dispensing tool	1	-
08485	12 fl. oz. High performance metal manual tool	1	20
08494	28 fl. oz. Standard all metal manual tool	1	-
08496	28 fl. oz. High performance pneumatic tool	1	-
DCE595D1	28 fl. oz. cordless 20v battery powered dispensing tool	1	-



Hole Cleaning Tools and Accessories

Cat. No.	Description	Std. Box
PFC1671050	Premium Wire brush for 7/16" ANSI hole	1
PFC1671100	Premium Wire brush for 1/2" hole	1
PFC1671150	Premium Wire brush for 9/16" ANSI hole	1
PFC1671200	Premium Wire brush for 5/8" ANSI hole	1
PFC1671225	Premium Wire brush for 11/16" ANSI hole	1
PFC1671250	Premium Wire brush for 3/4" ANSI hole	1
PFC1671300	Premium Wire brush for 7/8" ANSI hole	1
PFC1671350	Premium Wire brush for 1" ANSI hole	1
PFC1671400	Premium Wire brush for 1-1/8" ANSI hole	1
PFC1671450	Premium Wire brush for 1-3/8" ANSI hole	1
PFC1671500	Premium Wire brush for 1-1/2" ANSI hole	1
PFC1671830	Premium SDS-plus adapter for steel brushes	1
PFC1671000	Premium manual brush wood handle	1
PFC1671820	Premium Steel brush extension, 12" length	1
08292	Air compressor nozzle with extension, 18" length	1

Piston Plugs for Adhesive Anchors

Cat. #	Description	ANSI Drill Bit Dia.	Std. Bag
08258	11/16" Plug	11/16"	10
08259	3/4" Plug	3/4"	10
08300	7/8" Plug	7/8"	10
08301	1" Plug	1"	10
08303	1-1/8" Plug	1-1/8"	10
08307	1-1/4" Plug	1-1/4"	10
08305	1-3/8" Plug	1-3/8"	10
08309	1-1/2" Plug	1-1/2"	10

Piston Plugs for Post-Installed Rebar Connections

Cat. No.	Description	ANSI Drill Bit Dia.	Qty.
PFC1691520	3/4" Plug	3/4"	10
PFC1691530	7/8" Plug	7/8"	10
PFC1691540	1" Plug	1"	10
PFC1691550	1-1/8" Plug	1-1/8"	10
PFC1691555	1-1/4" Plug	1-1/4"	10
PFC1691560	1-3/8" Plug	1-3/8"	10
PFC1691570	1-1/2" Plug	1-1/2"	10

AC200+™
Acrylic Injection Adhesive Anchoring System



SDS Max 4-Cutter Carbide Drill Bits

Cat. No.	Diameter	Usable Length	Overall Length
DW5806	5/8"	8"	13-1/2"
DW5809	5/8"	16"	21-1/2"
DW5807	5/8"	31"	36"
DW5808	11/16"	16"	21-1/2"
DW5810	3/4"	8"	13-1/2"
DW5812	3/4"	16"	21-1/2"
DW5813	3/4"	31"	36"
DW5814	13/16"	16"	21-1/2"
DW5815	7/8"	8"	13-1/2"
DW5816	7/8"	16"	21-1/2"
DW5851	7/8"	31"	36"
DW5817	27/32"	16"	21-1/2"
DW5818	1"	8"	13-1/2"
DW5819	1"	16"	22-1/2"
DW5852	1"	24"	29"
DW5820	1"	31"	36"
DW5821	1-1/8"	10"	15"
DW5822	1-1/8"	18"	22-1/2"
DW5853	1-1/8"	24"	29"
DW5854	1-1/8"	31"	36"
DW5824	1-1/4"	10"	15"
DW5825	1-1/4"	18"	22-1/2"



SDS+ Full Head Carbide Drill Bits

Cat. No.	Diameter	Usable Length	Overall Length
DW5502	3/16"	2"	4-1/2"
DW5503	3/16"	4"	6-1/2"
DW5504	3/16"	5"	8-1/2"
DW5506	3/16"	10"	12"
DW5512	7/32"	8"	10"
DW5517	1/4"	4"	6"
DW5518	1/4"	6"	8-1/2"
DW55200	1/4"	10"	12"
DW5521	1/4"	12"	14"
DW5524	5/16"	4"	6"
DW5526	5/16"	10"	12"
DW5527	3/8"	4"	6-1/2"
DW5529	3/8"	8"	10"
DW55300	3/8"	10"	12"
DW5531	3/8"	16"	18"
DW5537	1/2"	4"	6"
DW5538	1/2"	8"	10-1/2"
DW5539	1/2"	10"	12"
DW5540	1/2"	16"	18"



SDS+ 4-Cutter Carbide Drill Bits

Cat. No.	Diameter	Usable Length	Overall Length
DW5471	5/8"	8"	10"
DW5472	5/8"	16"	18"
DW5474	3/4"	8"	10"
DW5475	3/4"	16"	18"
DW5477	7/8"	8"	10"
DW5478	7/8"	16"	18"
DW5479	1"	8"	10"
DW5480	1"	16"	18"
DW5481	1-1/8"	8"	10"
DW5482	1-1/8"	6"	18"

Dust Extraction

Cat. No.	Description
DWV012	10 Gallon Wet/Dry Hepa/Rrp Dust Extractor DWV9402 Fleece bag (5 pack) for DEWALT dust extractors DWV9316 Replacement Anti-Static Hose DWV9320 Replacement HEPA Filter Set (Type 1)
DWH050K	Dust Extraction with two interchangeable drilling heads
DCB1800M3T1	1800 Watt Portable Power Station & Parallel Battery Charger with 3 20V Max* 5Ah Batteries and 1 60V Max* Flexvolt® Battery



Hollow Drill Bits

	Cat. No.	Diameter	Overall Length	Usable Length	Recommended Hammer
SDS+	DWA54012	1/2"	14-1/2"	9-3/4"	DCH133 / DCH273 / DCH293
	DWA54916	9/16"	14-1/2"	9-3/4"	DCH133 / DCH273 / DCH293
	DWA54058	5/8"	14-1/2"	9-3/4"	DCH133 / DCH273 / DCH293
	DWA54034	3/4"	14-1/2"	9-3/4"	DCH133 / DCH273 / DCH293
SDS Max	DWA58058	5/8"	23-5/8"	15-3/4"	DCH481 / D25603K
	DWA58034	3/4"	23-5/8"	15-3/4"	DCH481 / D25603K
	DWA58078	7/8"	23-5/8"	15-3/4"	DCH481 / D25603K
	DWA58001	1"	23-5/8"	15-3/4"	DCH481 / D25603K
	DWA58118	1-1/8"	23-5/8"	15-3/4"	DCH481 / D25603K

