

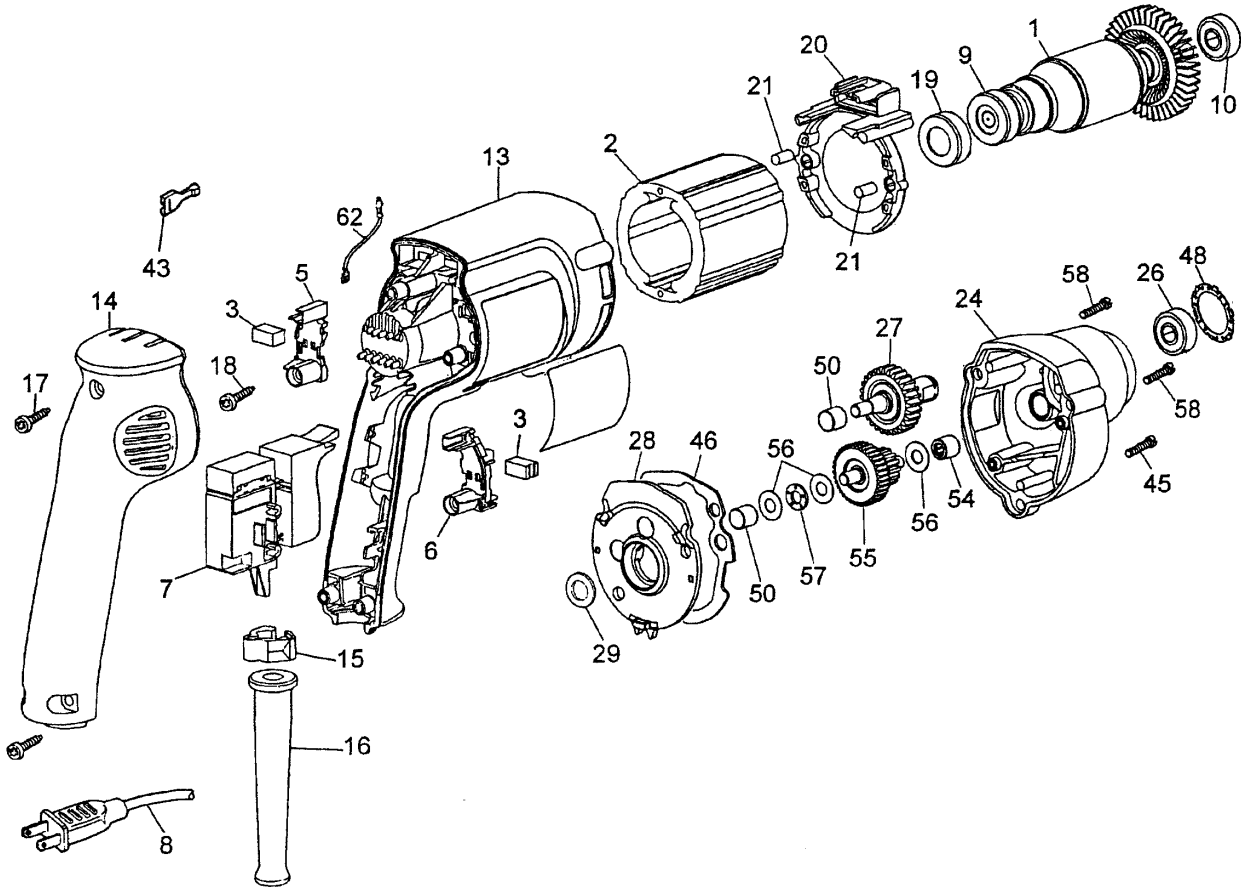

Component Motor Unit Model 253-55
 Used on KD-200, KD-242, KD-270, KD-280, KD-290 and KD-292 Shears;
 KS-221, KS-224, and KS-226 Saws

PARTS LIST



ITEM NO.	PART NO.	DESCRIPTION	REQ'D TOOL
1	382299-01	Armature & Fan (6 Teeth)	1
2	176883-00	Field	1
3	176846-02	Brush	2
4	176801-02	Left Brush Holder (gray)	1
5	176800-02	Right Brush Holder (black)	1
7	176830-13	Switch	1
*8	330072-98	Cord & Plug (18-2SJ)	1
*9	176950-00	Ball Bearing	1
*10	176950-00	Ball Bearing	1
13	396969-09	Field Case	1
14	176899-02	Handle Cover	1
*15	176829-00	Cord Clamp	1
16	330005-01	Cord Protector	1
*17	330019-13	Screw	3
*18	176951-00	Screw	2
*19	389824-00	Cup	1
20	176811-01	Baffle	1
21	949638-02	Rubber Plug	2
*24	388657-01	Gear Case	1
*26	330003-09	Ball Bearing	1
27	388668-01	Spindle & Gear	1
*28	176650-00	Gear Case Cover	1
*29	23813-00	Fiber Washer	1
43	136086-02	Terminal	3
*45	330019-14	Screw	1
46	176655-00	Gasket	1
*48	87692-00	Bearing Retainer	1

ITEM NO.	PART NO.	DESCRIPTION	REQ'D TOOL
*50	93128-00	Needle Bearing	2
*54	93129-00	Needle Bearing	1
55	176731-00	Pinion & Gear (15/37 teeth)	1
56	176732-00	Thrust Washer	3
57	143079-00	Thrust Washer	1
*58	330019-16	Screw	2
62	176860-00	Lead	1

***NOTES:**

- 8,15 Cord clamp should be positioned, so that 30mm of cord jacket extends above the clamp.
- 9 Seal to face commutator. Press to the tubing on armature shaft.
- 10 To remove from shaft, place bearing in vise and crush outer race. Remove all internal bearing components, so that the inner race is all that is left. Use SRT320, Small Bearing Separator, to clamp the inner race and press off. Bearing presses to shoulder.
- 17,45,58 Torque to 18-23 inch-lbs.
- 18 Torque to 13 inch-lbs.
- 19 Small diameter end to face commutator.
- 24 Includes 26,48 and 54.
- 26 Press Bearing until seated completely in pocket. Rubber seal to face spindle and gear assembly.
- 28 Includes 10 and 50.
- 29 Press to bearing (item 10).



Instructions for the Care of the Kett Scissor Shears Head

CAUTION:
Disconnect Power Unit
Before Servicing Tool

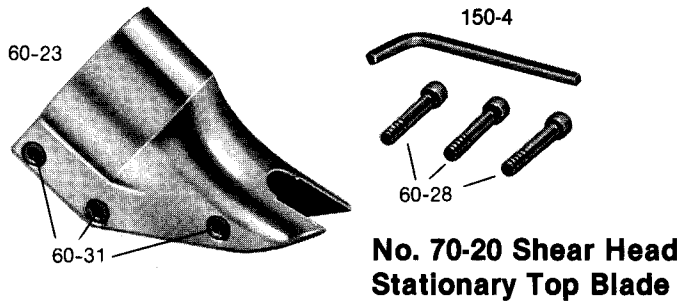

**No. 80-20 Shear Head
Stationary Bottom Blade**

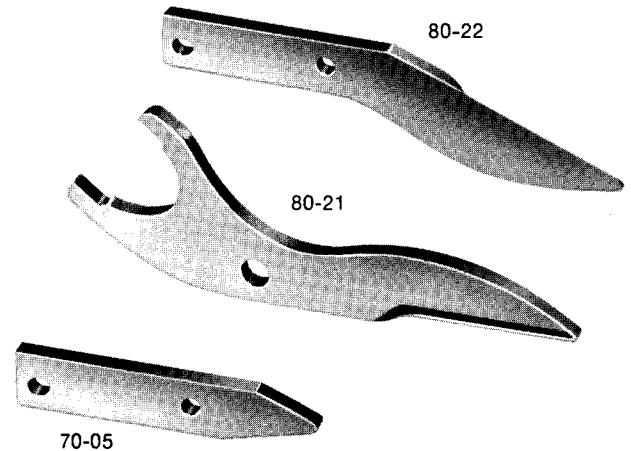
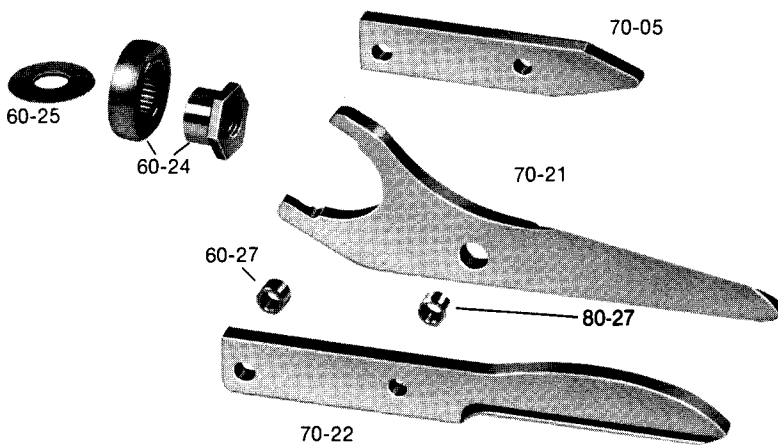

DISASSEMBLY

To remove shear head from motor loosen three cap screws (60-28). Remove shear head from motor by pulling head firmly forward. Slight twisting action may be required if head does not slide off easily.

To remove cutter blades from shear head remove three cap screws (60-28) completely from shear housing (60-23). Be careful not to lose rear spacer bushing (60-27) when removing middle cap screw. Remove center scissor blade from shear housing by tapping blade gently rearward. Be careful not to lose spacer bushing (80-27) from hole in center blade. Side knife and side spacer (70-05) will now drop out of the shear housing.

To remove eccentric bearing assembly (60-24) from shaft use an appropriate wrench to loosen eccentric nut by turning counter clockwise.

ASSEMBLY

To install eccentric bearing assembly (60-24) onto shaft make sure the large thin washer (60-25) is first inserted over shaft. Screw eccentric bearing assembly onto shaft and tighten with appropriate wrench. Lubricate bearing with a good grade of bearing grease.

To install cutter blades into shear housing (60-23) place the side knife and side spacer into position in the shear housing (60-23). Insert center cap screw (60-28) through side knife and side spacer with rear spacer bushing (60-27) between them and start cap screw into thread just enough to hold blades in place. **DO NOT TIGHTEN.** Insert spacer bushing (80-27) into hole in center scissor blade and lubricate with a good grade of bearing grease. Install center scissor blade into shear housing by tapping blade gently forward using a drift to line up hole in center blade with forward holes in housing. Insert and tighten forward cap screw (60-28) making sure spacer bushing (60-27) in center blade

60-23	Shearing Housing
60-24	Eccentric Bearing Assembly
60-25	Thin Washer, Large
60-27	Spacer Bushing
60-28	Cap Screw (3)
150-4	Allen Wrench
60-31	Knurled Insert (3)
70-05	Side Spacer
70-21	Center Scissor Blade
70-22	Side Knife
80-21	Center Scissor Blade
80-22	Side Knife
80-27	Spacer Bushing

stays in position. Apply good grade of bearing grease to clevis or yoke in center blade where it rides on the eccentric bearing assembly. Insert rear cap screw (60-28) into shear housing but do not completely tighten.

To install shear head assembly onto drive motor make sure all cap screws (60-28) are loosened about three or four complete turns. Place shear head onto unit and tighten cap screws snugly to lock head assembly in place. It may be necessary to gently tap the shear head into place if it does not readily slip onto the nose of the power unit.

SPECIAL SIDE KNIVES

For cutting woven wood or other rigid slat type materials side knives are available that do not have the wiping action of the standard Scissor Shears. These are: 75-22 Side Knife transforming the 70-20 Shear Head into the 75-20 Shear Head and the 85-22 Side Knife transforming the 80-20 Shear Head into the 85-20 Shear Head.