

Makita

Plate Joiner

MODEL 3901

INSTRUCTION MANUAL

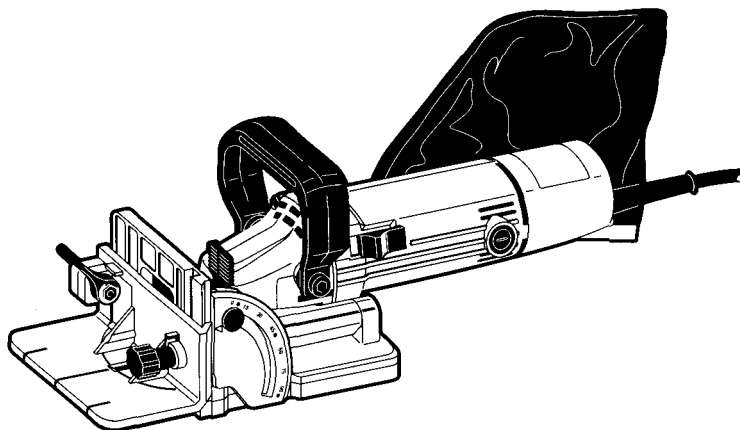

SPECIFICATIONS

Max. cutting capacities	No load speed (RPM)	Overall length	Net weight
20 mm (25/32")	10,000	307 mm (12-1/6")	2.8 kg (6.1 lbs)

* Manufacturer reserves the right to change specifications without notice.

* Note: Specifications may differ from country to country.

WARNING: For your personal safety, READ and UNDERSTAND before using.

SAVE THESE INSTRUCTIONS FOR FUTURE REFERENCE.

IMPORTANT SAFETY INSTRUCTIONS

(For All Tools)

WARNING: WHEN USING ELECTRIC TOOLS, BASIC SAFETY PRECAUTIONS SHOULD ALWAYS BE FOLLOWED TO REDUCE THE RISK OF FIRE, ELECTRIC SHOCK, AND PERSONAL INJURY, INCLUDING THE FOLLOWING:

READ ALL INSTRUCTIONS.

- 1. KEEP WORK AREA CLEAN.** Cluttered areas and benches invite injuries.
- 2. CONSIDER WORK AREA ENVIRONMENT.** Don't use power tools in damp or wet locations. Keep work area well lit. Don't expose power tools to rain. Don't use tool in presence of flammable liquids or gases.
- 3. KEEP CHILDREN AWAY.** All visitors should be kept away from work area. Don't let visitors contact tool or extension cord.
- 4. STORE IDLE TOOLS.** When not in use, tools should be stored in dry, and high or locked-up place — out of reach of children.
- 5. DON'T FORCE TOOL.** It will do the job better and safer at the rate for which it was intended.
- 6. USE RIGHT TOOL.** Don't force small tool or attachment to do the job of a heavy-duty tool. Don't use tool for purpose not intended; for example, don't use circular saw for cutting tree limbs or logs.
- 7. DRESS PROPERLY.** Don't wear loose clothing or jewelry. They can be caught in moving parts. Rubber gloves and non-skid footwear are recommended when working outdoors. Wear protective hair covering to contain long hair.
- 8. USE SAFETY GLASSES.** Also use face or dust mask if cutting operation is dusty.
- 9. DON'T ABUSE CORD.** Never carry tool by cord or yank it to disconnect from receptacle. Keep cord from heat, oil, and sharp edges.
- 10. SECURE WORK.** Use clamps or a vise to hold work. It's safer than using your hand and it frees both hands to operate tool.
- 11. DON'T OVERREACH.** Keep proper footing and balance at all times.
- 12. MAINTAIN TOOLS WITH CARE.** Keep tools sharp and clean for better and safer performance. Follow instructions for lubricating and changing accessories. Inspect tool cords periodically and if damaged, have repaired by authorized service facility. Inspect extension cords periodically and replace if damaged. Keep handles dry, clean, and free from oil and grease.
- 13. DISCONNECT TOOLS.** When not in use, before servicing, and when changing accessories, such as blades, bits, cutters.

14. **REMOVE ADJUSTING KEYS AND WRENCHES.** Form habit of checking to see that keys and adjusting wrenches are removed from tool before turning it on.
15. **AVOID UNINTENTIONAL STARTING.** Don't carry tool with finger on switch. Be sure switch is OFF when plugging in.
16. **EXTENSION CORDS.** Make sure your extension cord is in good condition. When using an extension cord, be sure to use one heavy enough to carry the current your product will draw. An undersized cord will cause a drop in line voltage resulting in loss of power and overheating. Table 1 shows the correct size to use depending on cord length and nameplate ampere rating. If in doubt, use the next heavier gauge. The smaller the gauge number, the heavier the cord.

TABLE 1 MINIMUM GAUGE FOR CORD SETS

		Total Length of Cord in Feet			
		0 – 25	26 – 50	51 – 100	101 – 150
Ampere Rating More Than	Not More Than	A W G			
0	6	18	16	16	14
6	10	18	16	14	12
10	12	16	16	14	12
12	16	14	12	Not Recommended	

17. **OUTDOOR USE EXTENSION CORDS.** When tool is used outdoors, use only extension cords intended for use outdoors and so marked.
18. **STAY ALERT.** Watch what you are doing, use common sense. Don't operate tool when you are tired.
19. **CHECK DAMAGED PARTS.** Before further use of the tool, a guard or other part that is damaged should be carefully checked to determine that it will operate properly and perform its intended function. Check for alignment of moving parts, binding of moving parts, breakage of parts, mounting, and any other conditions that may affect its operation. A guard or other part that is damaged should be properly repaired or replaced by an authorized service center unless otherwise indicated elsewhere in this instruction manual. Have defective switches replaced by authorized service center. Don't use tool if switch does not turn it on and off.
20. **GUARD AGAINST ELECTRIC SHOCK.** Prevent body contact with grounded surfaces. For example; pipes, radiators, ranges, refrigerator enclosures.
21. **REPLACEMENT PARTS.** When servicing, use only identical replacement parts.
22. **POLARIZED PLUGS.** To reduce the risk of electric shock, this equipment has a polarized plug (one blade is wider than the other). This plug will fit in a polarized outlet only one way. If the plug does not fit fully in the outlet, reverse the plug. If it still does not fit, contact a qualified electrician to install the proper outlet. Do not change the plug in any way.

VOLTAGE WARNING: Before connecting the tool to a power source (receptacle, outlet, etc.) be sure the voltage supplied is the same as that specified on the nameplate of the tool. A power source with voltage greater than that specified for the tool can result in **SERIOUS INJURY** to the user — as well as damage to the tool. If in doubt, **DO NOT PLUG IN THE TOOL**. Using a power source with voltage less than the nameplate rating is harmful to the motor.

ADDITIONAL SAFETY RULES

1. Use only the blades specified for this tool. This is extremely important for your personal safety.
2. Never operate the tool with the blade locked in exposed position or without the blade cover secured properly in place.
3. Make sure that the blade slides smoothly before operation.
4. Check the blade for cracks or damage before operation. Replace cracked or damaged blade immediately.
5. Make sure that the flange fits in the arbor hole when installing the blade.
6. Inspect for and remove all nails or foreign matter from the workpieces before operation.
7. Always place the workpiece on a stable workbench.
8. Secure the workpiece firmly with clamp or vise.
9. Never wear gloves during operation.
10. Hold the tool firmly with both hands.
11. Keep your hands and body away from the cutting area.
12. Run the tool for a while without the blade pointing toward anybody. Watch for vibration or wobbling that could indicate poor installation or a poorly balanced blade.
13. Never reach your hands underneath the workpieces while the blade is rotating.
14. Do not leave the tool running unattended.
15. Always be sure that the tool is switched off and unplugged before making any adjustments.

SAVE THESE INSTRUCTIONS.

Dust bag

To attach the dust bag, fit it onto the dust nozzle. If the dust bag becomes an obstacle to your work, turn the dust nozzle to change the dust bag position.

When the dust bag is about half full, switch off and unplug the tool. Remove the dust bag from the tool and pull the bag's fastener out. Empty the dust bag by tapping it lightly to remove as much of the dust as possible.

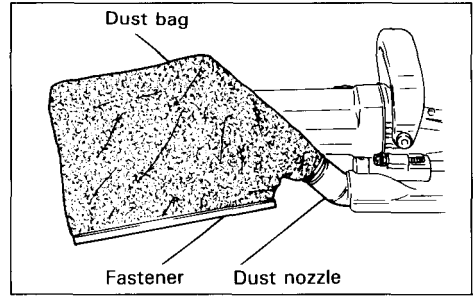

NOTE:

If you connect a Makita vacuum cleaner to your plate joiner, more efficient and cleaner operations can be performed.

Adjusting the depth of cut

6 cutting depths can be preset according to the size of biscuit to be used or if trimming the wall or ceiling panels as explained later. Rotate the stopper until the pointer points to the appropriate size marked on the stopper. Refer to the table below for the correspondence between the sizes marked on the stopper and the biscuit size. Fine adjustments to the cutting depth can be made by turning the adjusting screw after loosening the hex nut. This may become necessary after the blade has been resharpened a few times.

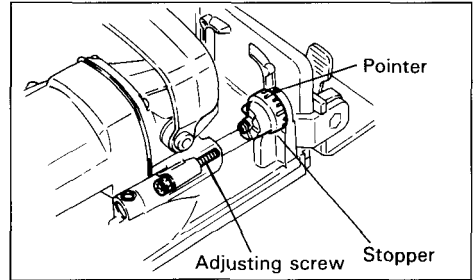

Size on stopper	0	10	20	S	D	MAX
Biscuit size	0	10	20	—	—	—
Depth of cut	8 mm (5/16")	10 mm (0.4")	12.3 mm (0.48")	13 mm (0.51")	14.7 mm (0.58")	20 mm (0.8")

Angle guide

The angle guide can be moved up and down to adjust the position of the blade in relation to the top of the workpiece. To adjust the angle guide height, loosen the lock lever and rotate the knob until the pointer points to the desired scale graduation marked on the angle guide. Then tighten the lock lever to secure the angle guide. The scale on the angle guide indicates the distance from the top of the workpiece to the center of the blade thickness.

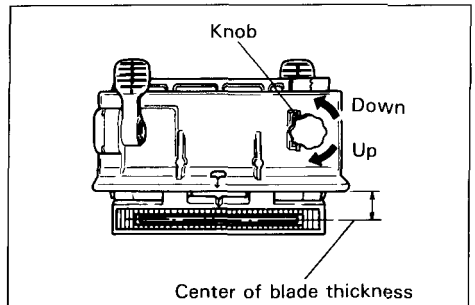
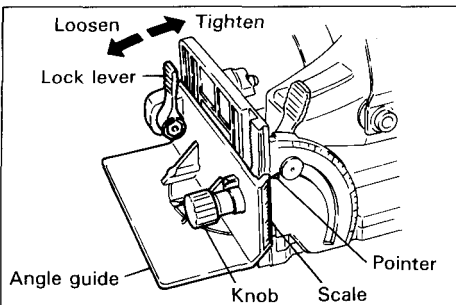

Fence

The angle of the fence can be adjusted between 0° and 90° (positive stops at 0°, 45° and 90°). To adjust the angle, loosen the lock lever and tilt the fence until the pointer points to the desired graduation on the angle scale. Then tighten the lock lever to secure the fence. When the fence is set at 90°, both the distance from the center of the blade thickness to the fence and the distance from the center of the blade thickness to the bottom of the base are 10 mm (0.4").

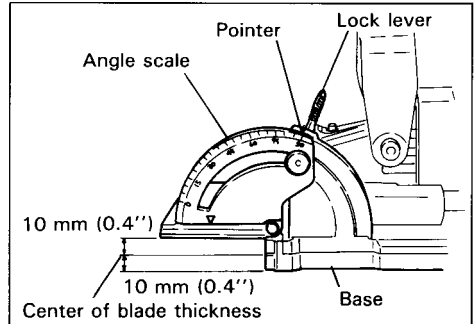
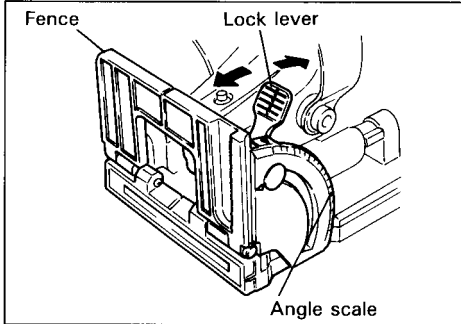

Set plate

Use the set plate as shown below when cutting slots in thin workpieces.

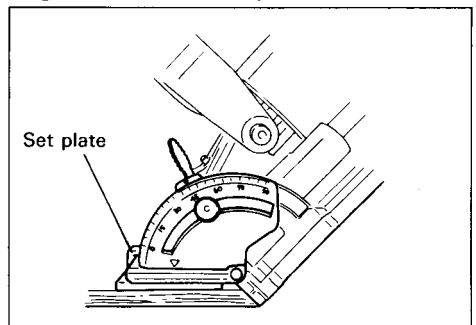
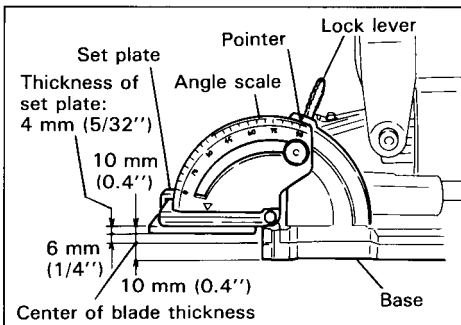

Switch action

To start the tool, slide the switch lever toward the "ON" position.
To stop the tool, simply depress the "OFF" side of the switch lever.
The switch lever will return to the "OFF" position.

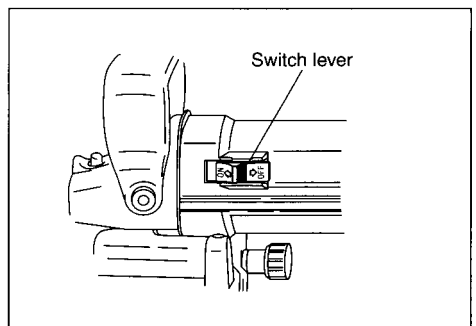

CAUTION:

Before plugging in the tool, always check to see that the switch actuates properly and returns to the "OFF" position when the "OFF" side of the switch lever is depressed. If not, then have it repaired by a qualified repair facility before use.

How to make joints

To make joints, proceed as follows:

1. Fit the two workpieces together as they will appear in the finished joint position.

Corner Joint

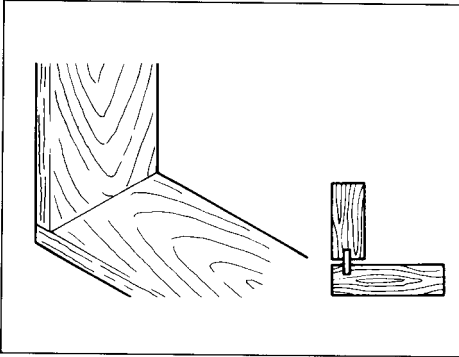

T-Butt Joint

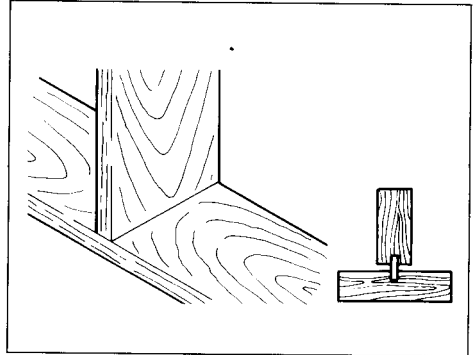

Miter Joint

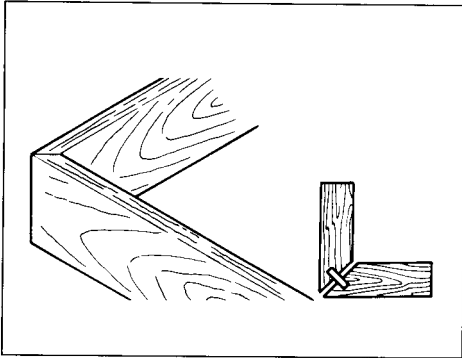

Frame Joint

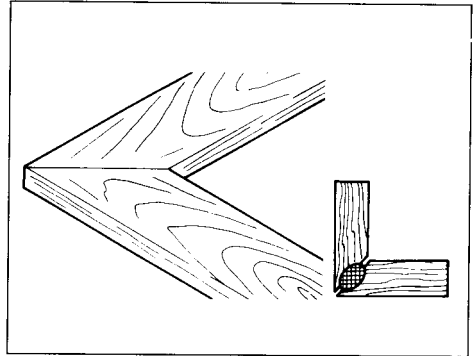

Edge-To-Edge Joint

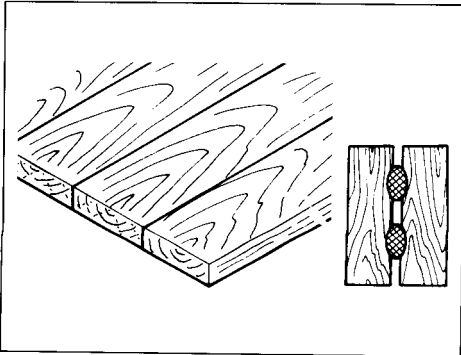

2. Mark the center of the intended biscuit slots on the workpiece using a pencil.

(Note)

- The center of slots should be at least 50 mm (2") from the outer edge of the workpieces.
- Allow 100 mm - 150 mm (4" - 6") between slots in multiple biscuit application.

3. For Corner Joint and T-Butt Joint only

Clamp the vertical workpiece to the workbench.

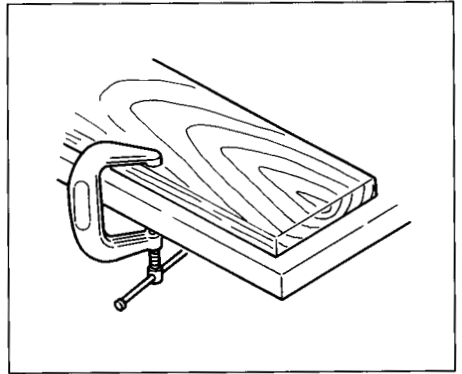

For Miter Joint only

Clamp one workpiece to the workbench with the mitered edge facing up.

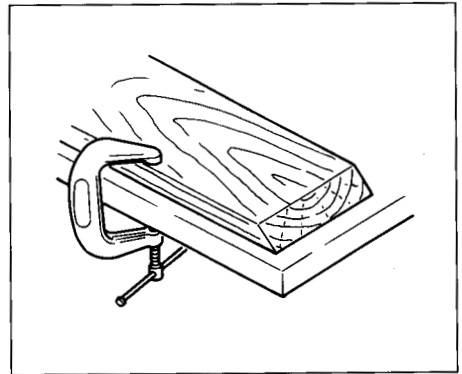

For Frame Joint and Edge-To-Edge Joint only

Clamp one workpiece to the workbench.

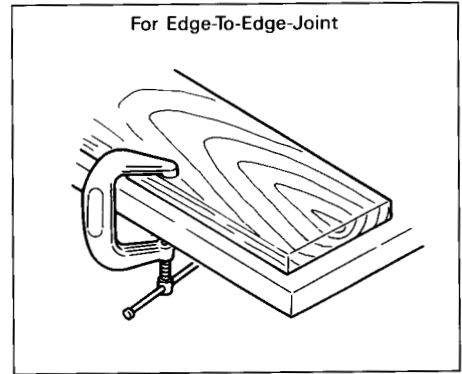
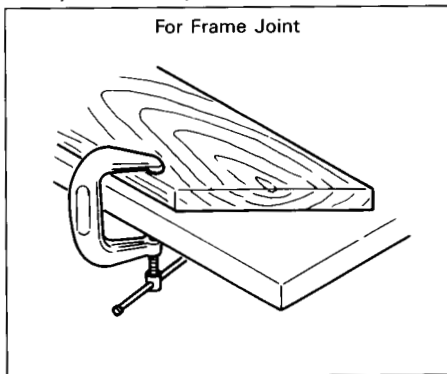

4. Set the depth of cut according to the size of biscuit to be used. Refer to the table in the "Adjusting the depth of cut" section.
5. Adjust the angle guide height so that the blade is centered in the board thickness.

6. Align the center mark on the base with the pencil line on the workpiece.

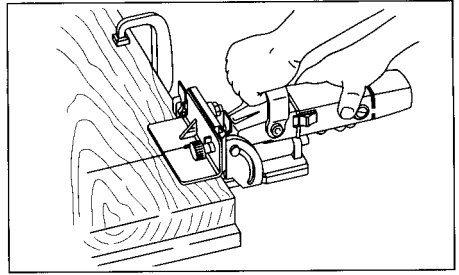

7. Switch on the tool and gently push it forward to extend the blade into the workpiece.
8. Gently return the tool to the original position after the adjusting screw reaches the stopper.
9. For Corner Joint and T-Butt Joint only

Clamp the horizontal workpiece to the workbench.

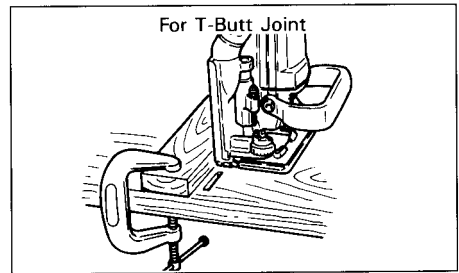
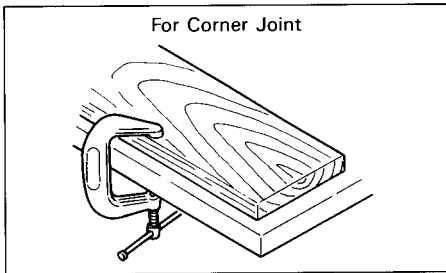

For Miter Joint only

Clamp the other workpiece to the workbench with the mitered edge facing up.

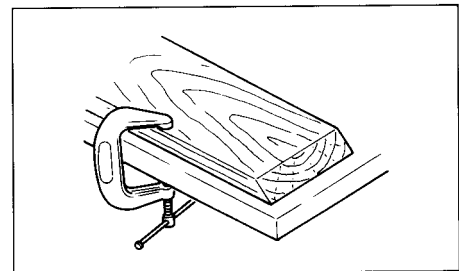

For Frame Joint and Edge-To-Edge Joint only
Clamp the other workpiece to the workbench.

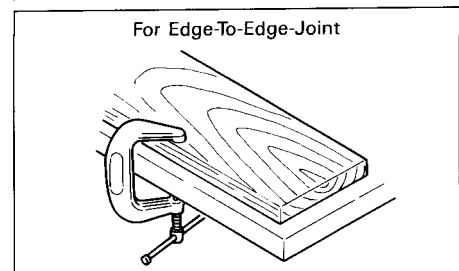
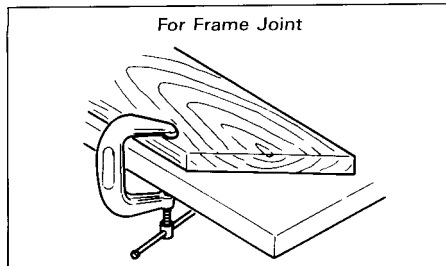

10. For Corner Joint only

Place the tool on the workpiece so that the blade is facing down.

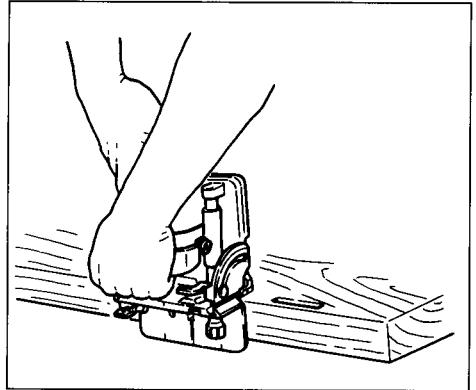

For T-Butt Joint only

Remove the angle guide from the tool. Place the tool on the workpiece so that the blade is facing down.

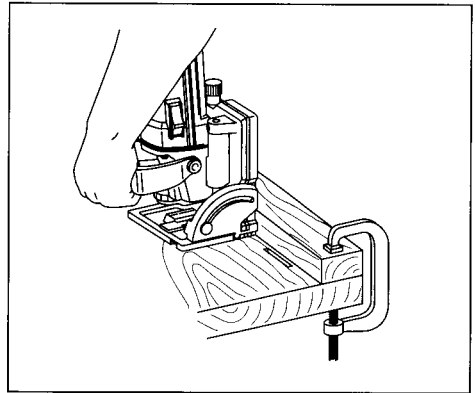

11. Repeat the steps 6 - 8 to cut the slots in the horizontal or the other workpiece.

If you do not need to center the blade in the board thickness, proceed as follows:

For Corner Joint, Miter Joint, Frame Joint and Edge-To-Edge Joint only

- i) Remove the angle guide from the tool. Set the fence at 90° for Corner Joint, Frame Joint and Edge-To-Edge Joint or at 45° for Miter Joint.
- ii) Follow steps 1 - 11 excluding steps 5 and 10 described above.

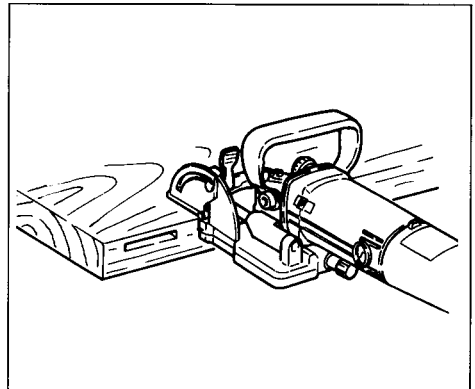

For T-Butt Joint only

- i) Fit the two workpieces together as they will appear in the finished joint position.
- ii) Lay the vertical workpiece on the horizontal one. Clamp both workpieces to the workbench as shown in the figure.
- iii) Remove the angle guide from the tool.
- iv) Follow the steps 2, 4, 6, 7, 8 and 11 described above.

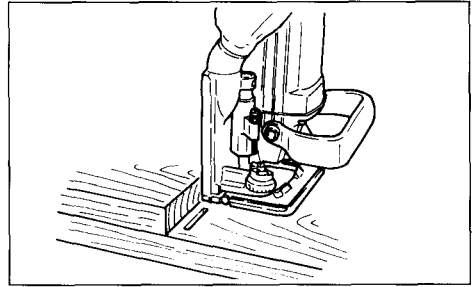
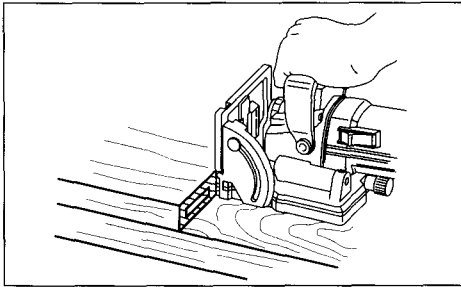

How to trim wall or ceiling panels

First unplug the tool. Open the blade cover and replace the existing cutter blade with an optional circular saw blade 110 mm (4-3/8") in diameter. Refer to the "Removing or installing the blade" section which is described later. Remove the rubber facing from the base. Then close and secure the blade cover. Now the max. depth of cut is 25 mm (1").

CAUTION:

Be very careful that the blade has been properly mounted on the tool spindle between the inner flange and the lock nut. Be sure to securely tighten the lock nut.

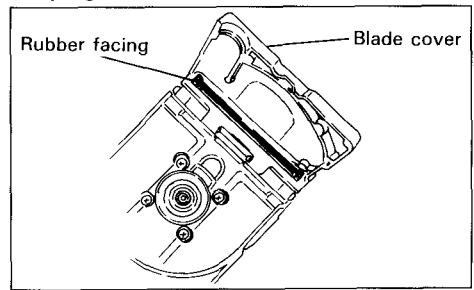
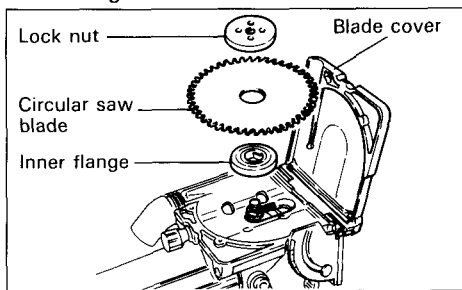

Set the depth of cut to "MAX". Rest the base on the floor (when trimming the wall panels) or the wall (when trimming the ceiling panels). Using the floor or wall as a guide, trim wall or ceiling panels. Feed in the direction of the arrow.

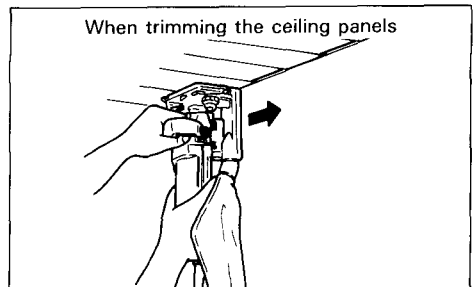
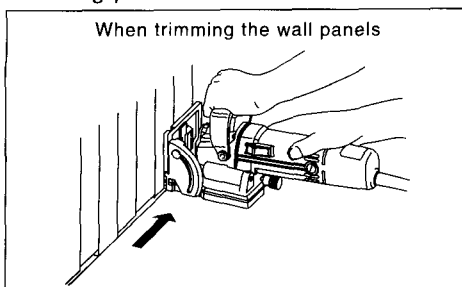

CAUTION:

- Before trimming the panels, check the wall or ceiling carefully to avoid cutting the electrical wires, nails or other foreign materials.
- Always reinstall the rubber facing after trimming the panels. If cutting slots for biscuits without the rubber facing installed properly on the tool, the tool might slip unexpectedly on the workpiece, causing dangerous loss of control of the tool. When installing the rubber facing, always hook it onto the inside of the front opening.

Removing or installing the blade

CAUTION:

Always be sure that the tool is switched off and unplugged before removing or installing the blade.

To remove the blade, loosen the clamp screw and open the blade cover. Push the shaft lock and loosen the lock nut using the lock nut wrench.

To install the blade, first mount the inner flange.

CAUTION:

- When installing the cutter blade, mount the inner flange with the side marked "22" facing toward you.
- When installing the circular saw blade, mount the inner flange with the side marked "22" facing toward the tool.

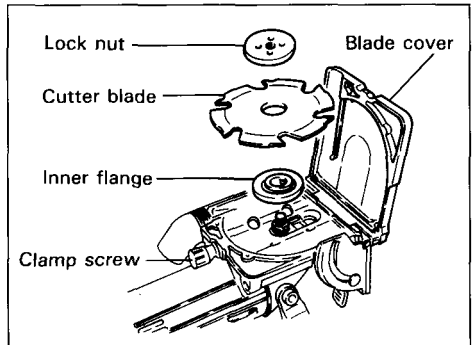

Then mount the blade and the lock nut. Securely tighten the lock nut using the lock nut wrench. Close the blade cover and tighten the clamp screw to secure the blade cover.

CAUTION:

- Use only the Makita lock nut wrench provided to remove or install the blade.
- Always check the depth of cut after replacing the blade. Readjust it if necessary.

MAINTENANCE

CAUTION:

Always be sure that the tool is switched off and unplugged before attempting to perform inspection or maintenance.

Replacing carbon brushes

Remove and check the carbon brushes regularly. Replace when they wear down to the limit mark. Keep the carbon brushes clean and free to slip in the holders. Both carbon brushes should be replaced at the same time. Use only identical carbon brushes.

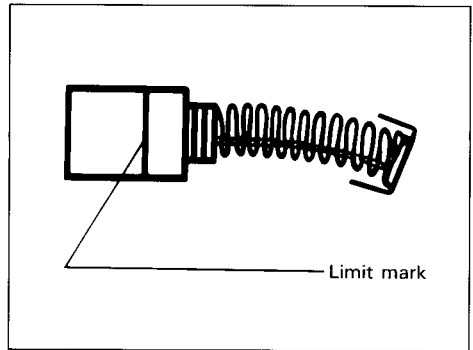

Use a screwdriver to remove the brush holder caps. Take out the worn carbon brushes, insert the new ones and secure the brush holder caps.

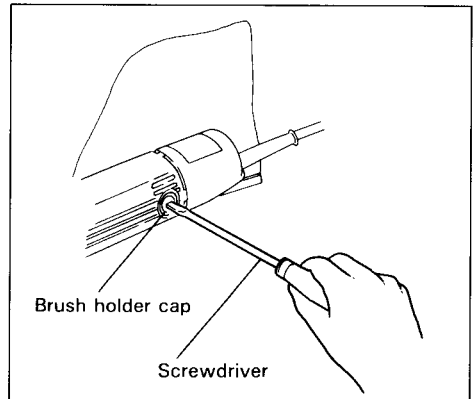

To maintain product SAFETY and RELIABILITY, repairs, any other maintenance or adjustment should be performed by Makita Authorized or Factory Service Centers, always using Makita replacement parts.

OPTIONAL ACCESSORIES

The accessories listed in this manual are available at an extra cost from your Makita distributor or Makita factory service center. Service centers are listed on the warranty card packed with your tool.

CAUTION:

These accessories or attachments are recommended for use with your Makita tool specified in this manual. The use of any other accessories or attachments might present a risk of injury to persons. The accessories or attachments should be used only in the proper and intended manner.

- **Angle guide**

Part No. 122473-8

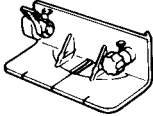

- **Dust bag**

Part No. 122474-6

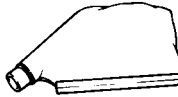

- **Set plate 4**

Part No. 415579-2

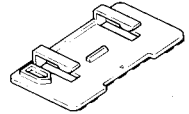

- **Lock nut wrench 20**

Part No. 782401-1



- **Plastic tool case**

Part No. A00471-9



- **Cutter blade 100-4**

Carbide-tipped
plate joiner blade



Part No.	Diameter (mm)	Hole diameter (mm)	No. Teeth
732215-8	100 (4")	22 (7/8")	6

- **Combination saw blade**

For rip and cross-cut work.
Has fewer teeth than
cross-cut blade for
faster cutting.

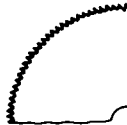

Part No.	Diameter (mm)	Hole diameter (mm)	No. Teeth
792010-8	110 (4-3/8")	20 (3/4")	50

- **Cross-cut saw blade**

For smoother cross-cut work.
Makes smoother cuts than
combination blade.

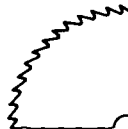

Part No.	Diameter (mm)	Hole diameter (mm)	No. Teeth
792012-4	110 (4-3/8")	20 (3/4")	60

- **Carbide-tipped saw blade**

Faster, smoother, longer sawing
without blade sharpening.
Cuts wood, dry wall, plastics,
hard wood, etc.

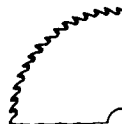

Part No.	Diameter (mm)	Hole diameter (mm)	No. Teeth
792015-8	110 (4-3/8")	20 (3/4")	4

PLATE JOINER Model 3901

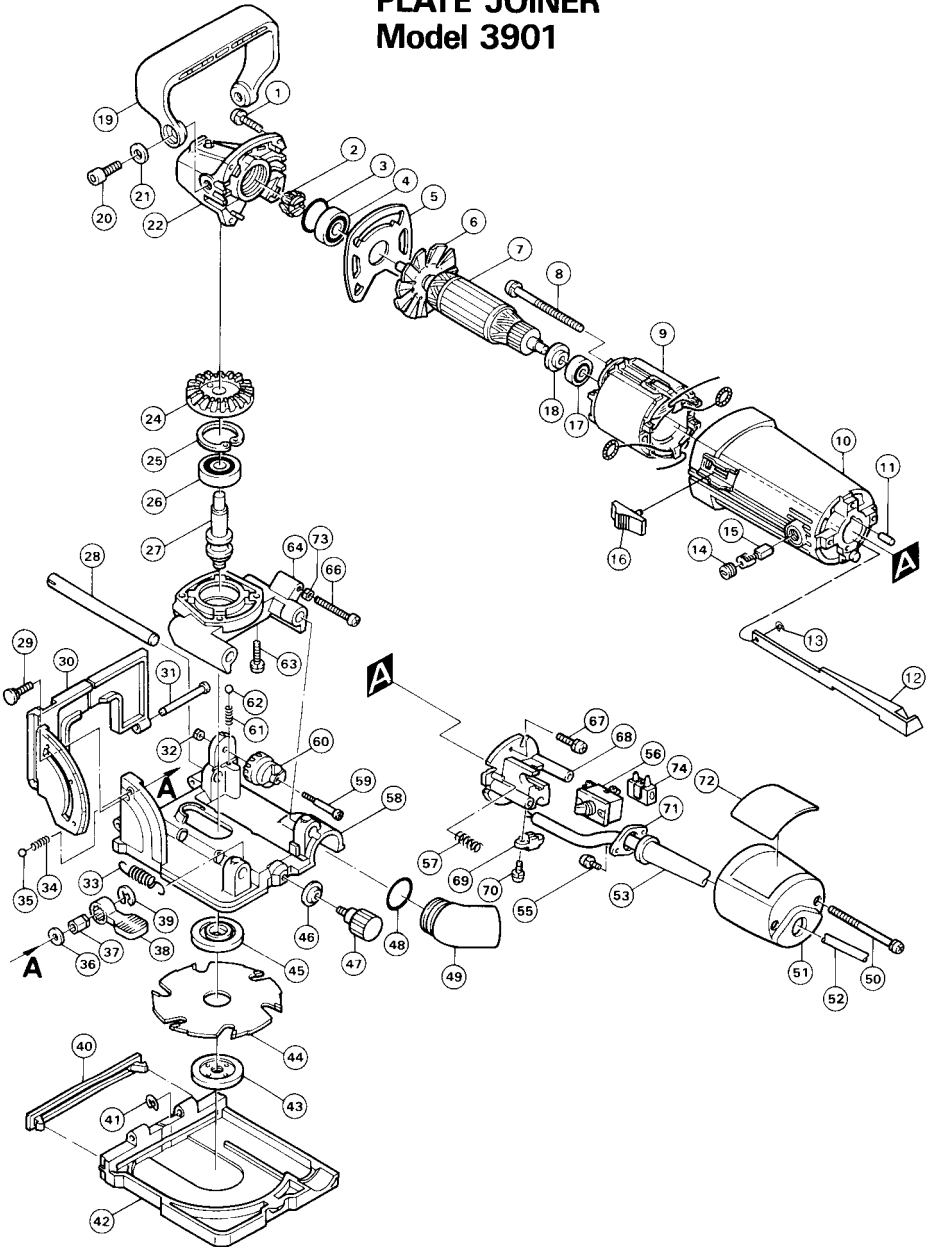

Note: The switch and other part configurations may differ from country to country.

Item No.	Qty. Used	Description	Item No.	Qty. Used	Description
MACHINE			MACHINE		
1	4	Pan Head Screw M4 x 20 (With Washer)	37	1	Hex. Nut M6
2	1	Spiral Bevel Gear 11	38	1	Lever 40
3	1	O Ring 26	39	1	Stop Ring E-8
4	1	Ball Bearing 6000DDW	40	1	Rubber Facing
5	1	Plate	41	2	Stop Ring E-3
6	1	Fan 60	42	1	Blade Cover
7	1	ARMATURE ASSEMBLY (With Item 6, 17 & 18)	43	1	Lock Nut 10-40
8	2	Pan Head Screw M4x70 (With Washer)	44	1	Cutter 100-4
9	1	FIELD ASSEMBLY	45	1	Inner Flange 40
10	1	Motor Housing	46	1	Leaf Spring
11	1	Rubber Pin 4	47	1	Screw M5x10
12	1	Switch Rod	48	1	O Ring 24
13	1	Stop Ring E-2.3	49	1	Dust Nozzle
14	2	Brush Holder Cap	50	2	Pan Head Screw M4x60 (With Washer)
15	2	Carbon Brush	51	1	Rear Cover
16	1	Switch Lever	52	1	Cord
17	1	Ball Bearing 627LLB	53	1	Cord Guard
18	1	Insulation Washer	55	2	Pan Head Screw M4x10 (With Washer)
19	1	Grip	56	2	Switch
20	2	Hex. Socket Head Bolt M8x16	57	2	Compression Spring 6
21	2	Flat Washer 8	58	1	Base
22	1	Gear Housing	59	1	Pan Head Screw M4
24	1	Spiral Bevel Gear 36	60	1	Stopper
25	1	Retaining Ring R-32	61	1	Compression Spring 2.4
26	1	Ball Bearing 6201LLB	62	1	Steel Ball 3.5
27	1	Spindle	63	4	Pan Head Screw M4x20 (With Washer)
28	2	Rod 10	64	1	Bearing Box
29	1	Cap Square Neck Bolt M6x20	66	1	Pan Head Screw M5x45
30	1	Fence	67	2	Pan Head Screw M4x18 (With Washer)
31	2	Pin 4	68	1	Switch Holder
32	1	Hex. Nut M4	69	1	Strain Relief
33	2	Tension Spring 8	70	2	Pan Head Screw M4x14 (With Washer)
34	1	Compression Spring 2.4	71	1	Set Plate
35	1	Steel Ball 3.5	72	1	Name Plate
36	1	Flat Washer 6	73	1	Hex. Nut M5
			74	1	Terminal Block

Note: The switch and other part specifications may differ from country to country

MAKITA LIMITED ONE YEAR WARRANTY

Warranty Policy

Every Makita tool is thoroughly inspected and tested before leaving the factory. It is warranted to be free of defects from workmanship and materials for the period of ONE YEAR from the date of original purchase. Should any trouble develop during this one-year period, return the COMPLETE tool, freight prepaid, to one of Makita's Factory or Authorized Service Centers. If inspection shows the trouble is caused by defective workmanship or material, Makita will repair (or at our option, replace) without charge.

This Warranty does not apply where:

- repairs have been made or attempted by others;
- repairs are required because of normal wear and tear;
- The tool has been abused, misused or improperly maintained;
- alterations have been made to the tool.

IN NO EVENT SHALL MAKITA BE LIABLE FOR ANY INDIRECT, INCIDENTAL OR CONSEQUENTIAL DAMAGES FROM THE SALE OR USE OF THE PRODUCT. THIS DISCLAIMER APPLIES BOTH DURING AND AFTER THE TERM OF THIS WARRANTY.

MAKITA DISCLAIMS LIABILITY FOR ANY IMPLIED WARRANTIES, INCLUDING IMPLIED WARRANTIES OF "MERCHANTABILITY" AND "FITNESS FOR A SPECIFIC PURPOSE," AFTER THE ONE-YEAR TERM OF THIS WARRANTY.

This Warranty gives you specific legal rights, and you may also have other rights which vary from state to state. Some states do not allow the exclusion or limitation of incidental or consequential damages, so the above limitation or exclusion may not apply to you. Some states do not allow limitation on how long an implied warranty lasts, so the above limitation may not apply to you.

Makita Corporation of America
 2650 Gainesville Hwy., Buford, GA 30518