



# SERVICE PARTS LIST

**BULLETIN NO.**  
**54-40-2600**

SPECIFY CATALOG NO. AND SERIAL NO. WHEN ORDERING PARTS		REVISED BULLETIN	DATE
<b>CORDLESS 18V COMPACT BAND SAW</b>			Sept. 2009
CATALOG NO.	2629-20	STARTING SERIAL NO.	C14A
		WIRING INSTRUCTION <b>SEE PAGES 4, 5, 6 &amp; 7</b>	

**EXAMPLE:**  
00 0 Component Parts (Small #)  
Are Included When Ordering  
The Assembly (Large #).

FIG.	PART NO.	DESCRIPTION OF PART	NO. REQ.
35	06-82-5574	10-24 x 7/8" Pan Hd. Tapt. T-25 Screw	(7)
36	06-82-0035	M5 Pan Hd. T-20 Screw	(3)
39	-----	Deck	(1)
47	22-22-0140	Brush Card Assembly	(1)
48	22-56-0150	Wire Nut (C1 & C2)	(2)

50	18-01-3015	Service Field	(1)
52	16-01-3091	Service Armature	(1)
53	05-78-0305	Switch Screw	(4)
54	45-88-1890	Spring Washer	(4)
55	06-82-5320	8-32 x 5/8" Pan Hd. Slit. Tapt. T-20 Screw	(3)
56	28-28-0060	Diaphragm	(1)
57	02-04-0645	Ball Bearing	(1)
58	-----	1st Gear	(1)
59	-----	Ball Bearing	(1)
60	-----	2nd Bevel Pinion	(1)
61	-----	Bevel/Spur Gear	(1)
62	-----	Needle Bearing	(2)
63	-----	Gearcase	(1)
64	02-04-0135	Ball Bearing	(1)
66	45-30-0255	Rubber Slug	(4)
67	-----	3rd Gear	(1)
68	-----	Pulley Shaft	(1)
69	43-96-0105	Key	(1)
70	02-04-1525	Ball Bearing	(1)
71	45-88-0406	Washer	(1)
72	28-14-0180	Bearing Plate Bottom	(1)
73	06-82-7261	6-19 x 11/16" Pan Hd. Slit. Plast. T-15 Screw	(2)
74	06-82-7270	8-16 x 5/8" Pan Hd. Slit. Plast. T-20 Screw	(12)
75	-----	Handle - Left	(1)
76	40-50-0650	Compression Spring	(1)
77	-----	Terminal Block Assembly	(1)
78	42-55-0100	Carrying Case	(1)
79	06-82-5294	1/4-20 x 3/4" Pan Hd. Tapt. T-30 Screw	(2)
80	23-66-1000	Switch	(1)
81	06-82-7251	8-16 x 3/8" Pan Hd. Slit. Plast. T-20 Screw	(1)
82	-----	Lock-Off Shuttle	(1)
83	-----	Detent Spring	(1)
84	10-20-1865	LED Label	(1)
85	-----	PCB	(1)
86	-----	Handle - Right	(1)
87	06-82-0045	3/8"-16 UNC-3A Hex Recess Screw	(1)
88	31-44-0095	Front T-Handle	(1)
89	06-82-5316	8-32 x 1/2" Pan Hd. Slit. Tapt. T-20 Screw	(2)
90	45-88-0825	Washer	(2)
91	-----	Motor Cover	(1)
92	-----	Wire Assembly	(1)
93	-----	LED Switch Box	(1)
94	31-44-0305	Handle Kit	(1)
95	31-15-0205	Motor Cover Assembly	(1)
96	28-90-0015	Deck Assembly	(1)
105	32-60-0055	Bevel Pinion Assembly	(1)
106	32-05-0035	Bevel/Spur Gear Assembly	(1)
107	14-73-0040	Pulley Gear Assembly	(1)
108	14-30-0050	Top Gearcase Assembly	(1)
109	45-24-0055	Shuttle Lock-Off Kit	(1)
110	14-20-0025	Electronics Kit	(1)

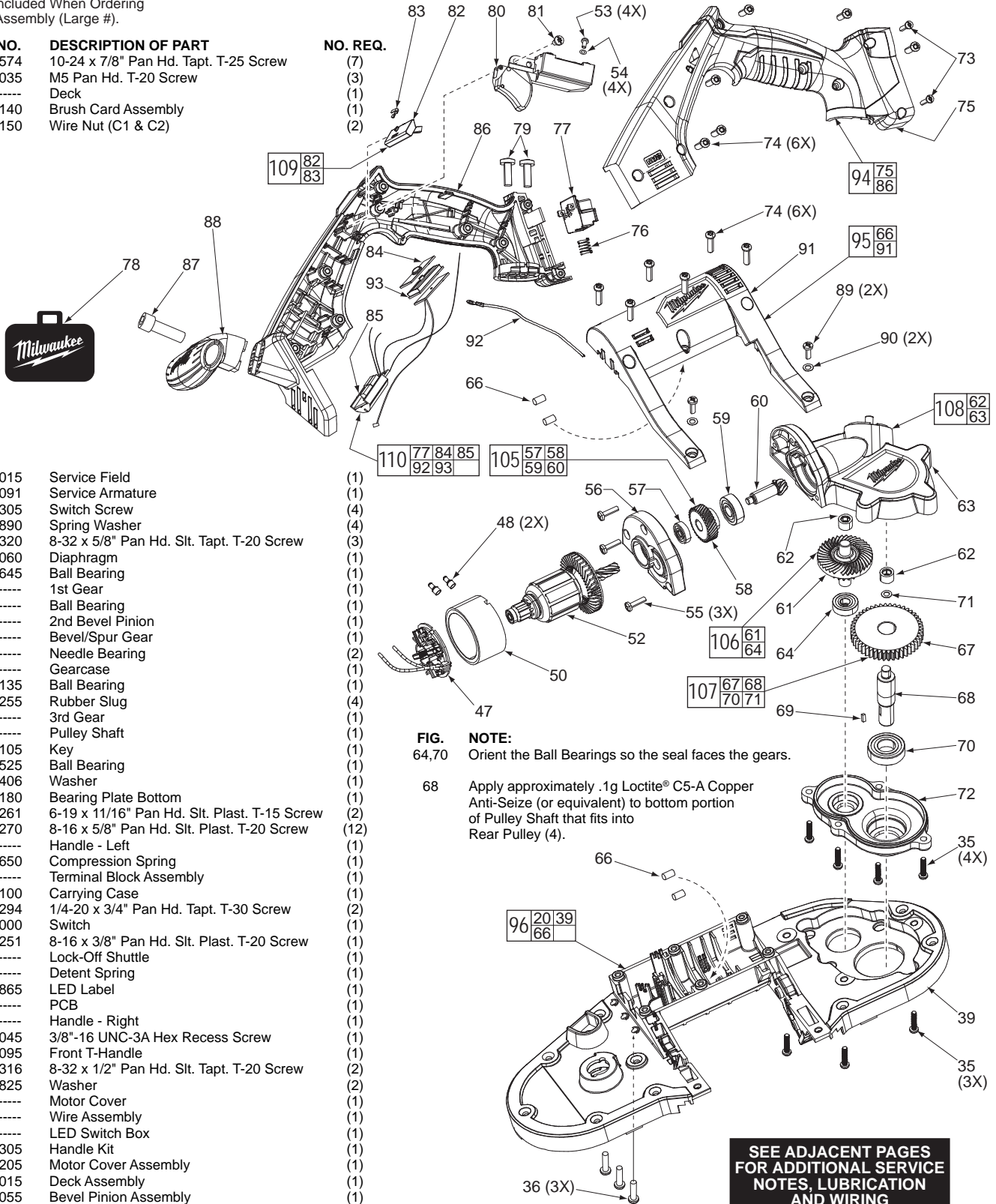

**FIG. NOTE:**  
64,70 Orient the Ball Bearings so the seal faces the gears.

68 Apply approximately .1g Loctite® C5-A Copper Anti-Seize (or equivalent) to bottom portion of Pulley Shaft that fits into Rear Pulley (4).

**SEE ADJACENT PAGES FOR ADDITIONAL SERVICE NOTES, LUBRICATION AND WIRING**

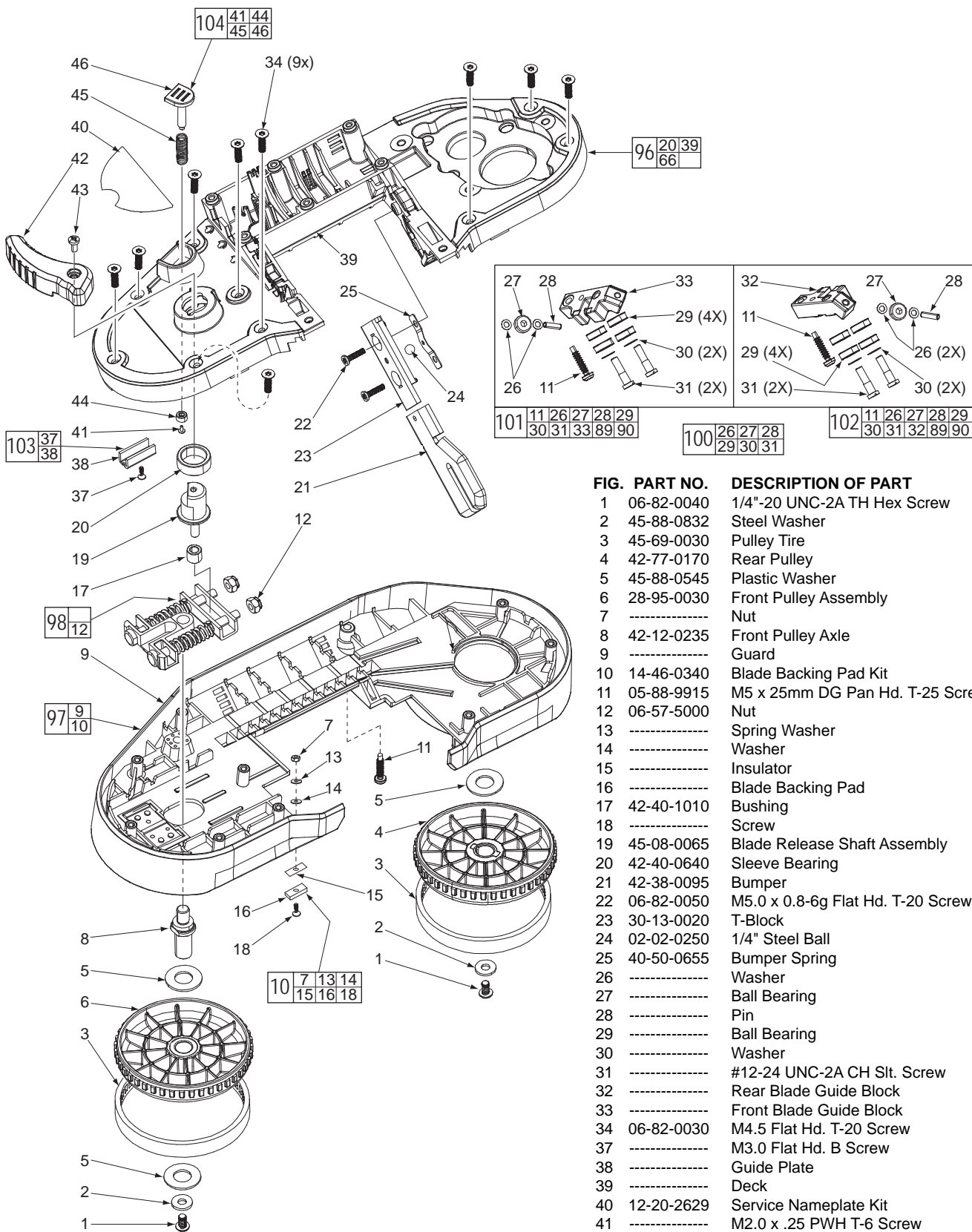
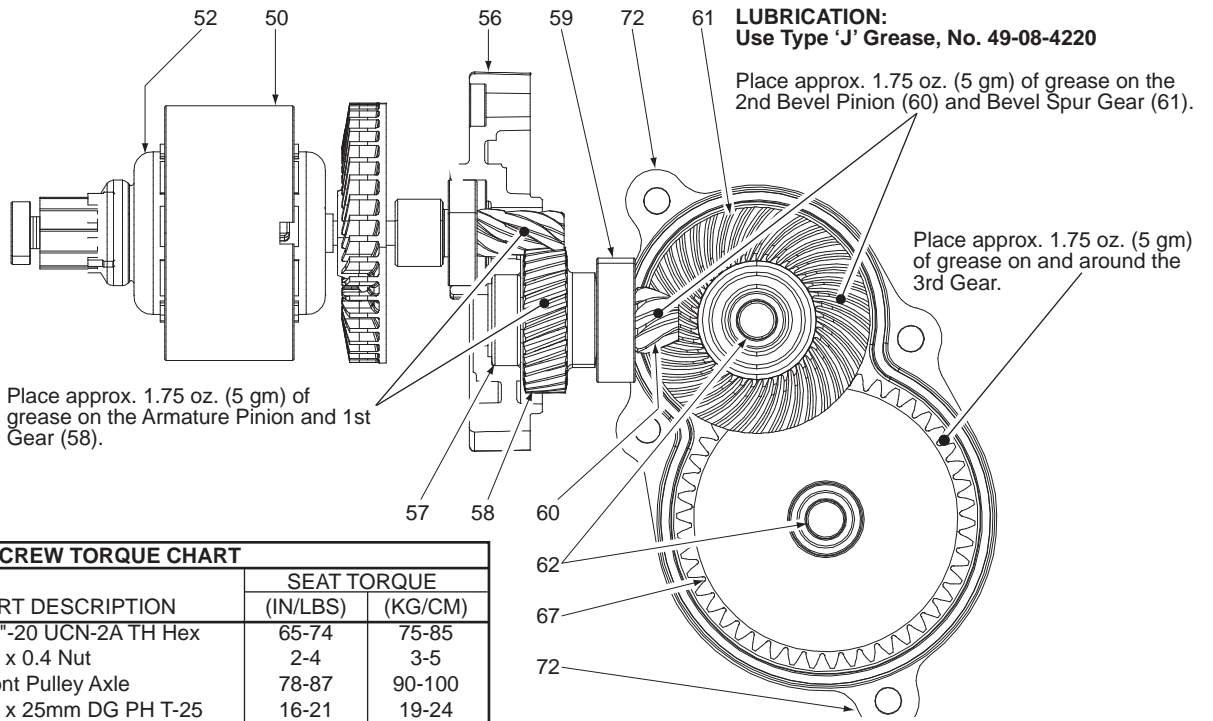
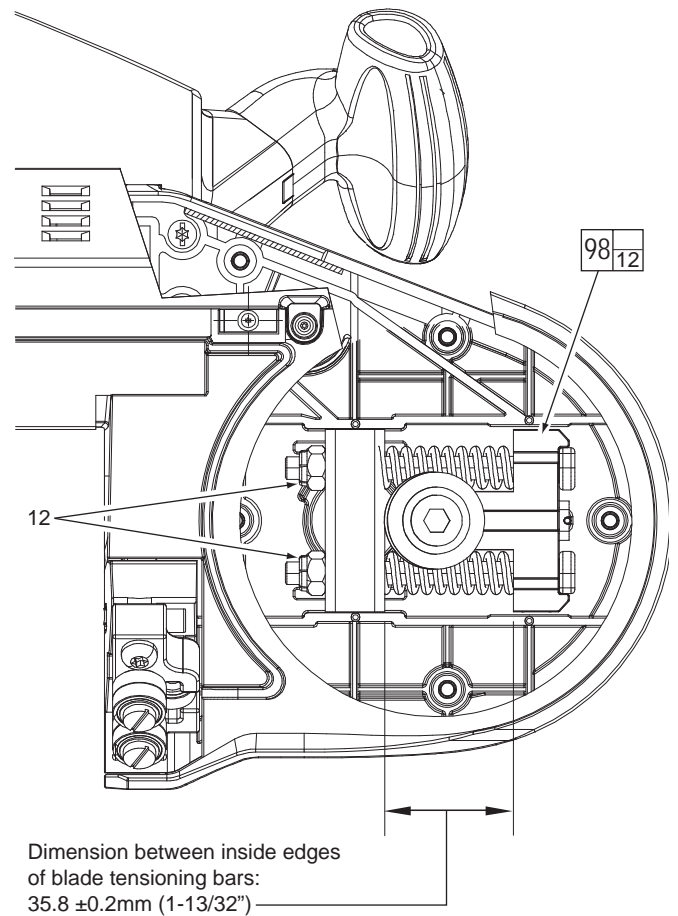

FIG.	PART NO.	DESCRIPTION OF PART	NO. REQ.
1	06-82-0040	1/4"-20 UNC-2A TH Hex Screw	(2)
2	45-88-0832	Steel Washer	(2)
3	45-69-0030	Pulley Tire	(2)
4	42-77-0170	Rear Pulley	(1)
5	45-88-0545	Plastic Washer	(3)
6	28-95-0030	Front Pulley Assembly	(1)
7	-----	Nut	(1)
8	42-12-0235	Front Pulley Axle	(1)
9	-----	Guard	(1)
10	14-46-0340	Blade Backing Pad Kit	(1)
11	05-88-9915	M5 x 25mm DG Pan Hd. T-25 Screw	(3)
12	06-57-5000	Nut	(2)
13	-----	Spring Washer	(1)
14	-----	Washer	(1)
15	-----	Insulator	(1)
16	-----	Blade Backing Pad	(1)
17	42-40-1010	Bushing	(1)
18	-----	Screw	(1)
19	45-08-0065	Blade Release Shaft Assembly	(1)
20	42-40-0640	Sleeve Bearing	(1)
21	42-38-0095	Bumper	(1)
22	06-82-0050	M5.0 x 0.8-6g Flat Hd. T-20 Screw	(2)
23	30-13-0020	T-Block	(1)
24	02-02-0250	1/4" Steel Ball	(1)
25	40-50-0655	Bumper Spring	(1)
26	-----	Washer	(4)
27	-----	Ball Bearing	(2)
28	-----	Pin	(2)
29	-----	Ball Bearing	(8)
30	-----	Washer	(4)
31	-----	#12-24 UNC-2A CH Slit. Screw	(4)
32	-----	Rear Blade Guide Block	(1)
33	-----	Front Blade Guide Block	(1)
34	06-82-0030	M4.5 Flat Hd. T-20 Screw	(9)
37	-----	M3.0 Flat Hd. B Screw	(1)
38	-----	Guide Plate	(1)
39	-----	Deck	(1)
40	12-20-2629	Service Nameplate Kit	(1)
41	-----	M2.0 x .25 PWH T-6 Screw	(1)
42	45-08-0490	Blade Release Lever	(1)
43	06-82-7252	8-32 x 3/8" Pan Hd. Slit. Tapt. T-20 Screw	(1)
44	-----	Bushing	(1)
45	-----	Spring	(1)
46	-----	Blade Ejection Pin	(1)
96	28-90-0015	Deck Assembly	(1)
97	28-41-0050	Guard Assembly	(1)
98	42-18-0025	Blade Tension Bar Assembly	(1)
100	14-46-0465	Guide Block Hardware Kit	(1)
101	42-28-0410	Front Guide Block Assembly	(1)
102	42-28-0420	Rear Guide Block Assembly	(1)
103	44-66-0325	Guide Plate Kit	(1)
104	44-60-0240	Blade Ejection Shaft Kit	(1)

- FIG. NOTE:**
- 24 Apply Loctite® Silver Grade Anti-Seize Stick 80209 (or equivalent) to Steel Ball.
  - 8 Apply Loctite® Cleaner 755 (or equivalent) to Front Pulley Axle thread first then place a drop or two of Blue Loctite® 443 (or equivalent) to axle threads.
  - 18,41 Apply a drop of Blue Loctite® 443 (or equivalent) to threads of each screw.
  - 9,38 Apply Loctite® C5-A Copper Anti-Seize (or equivalent) to metal insert in Guard and to Guide Plate. Approximately .1g for each part.



SCREW TORQUE CHART				
ITEM	PART NO.	PART DESCRIPTION	SEAT TORQUE	
			(IN/LBS)	(KG/CM)
1	06-82-0040	1/4"-20 UCN-2A TH Hex	65-74	75-85
7	-----	M2 x 0.4 Nut	2-4	3-5
8	42-12-0235	Front Pulley Axle	78-87	90-100
11	05-88-9915	M5 x 25mm DG PH T-25	16-21	19-24
12	06-57-5000	Flex-Loc Nut	To Assembly Length	
18	-----	M2 x 0.4 T-6	2-4	3-5
22	06-82-0050	M5 x .8-6g FH T-20	26-30	30-35
31	06-82-0120	#12-24 UNC-2A CH Slotted	39-48	45-55
34	06-82-0030	M4.5 FH T-20	16-21	19-24
35	06-82-5574	#10-24 x 7/8" PH T-25	39-48	45-55
36	06-82-0035	M5.0 PH T-20	22-26	25-30
37	06-82-0010	M3 FH B	6-9	7-10
41	06-82-0025	M2.0 x .25 PWH T-6	2-4	3-5
43	06-82-7252	#8-32 x 3/8" PH T-20	22-26	25-30
55	06-82-5320	#8-32 x 5/8" PH T-20	26-31	30-36
73	06-82-7261	#6-19 x 11/16" PH T-15	16-21	19-24
74	06-82-7270	#8-16 x 5/8" PH T-20	16-21	19-24
79	06-82-5294	1/4"-20 UNC-2A PH T-30	65-74	75-85
81	06-82-7251	#8-16 x 3/8" PH T-20	10-14	12-16
87	06-82-0045	3/8"-16 UNC-3A T-20	87-104	100-120
89	06-82-5316	#8-32 x 1/2" PH T-20	16-21	19-24



# WIRING INSTRUCTIONS- From Terminal Block Assembly

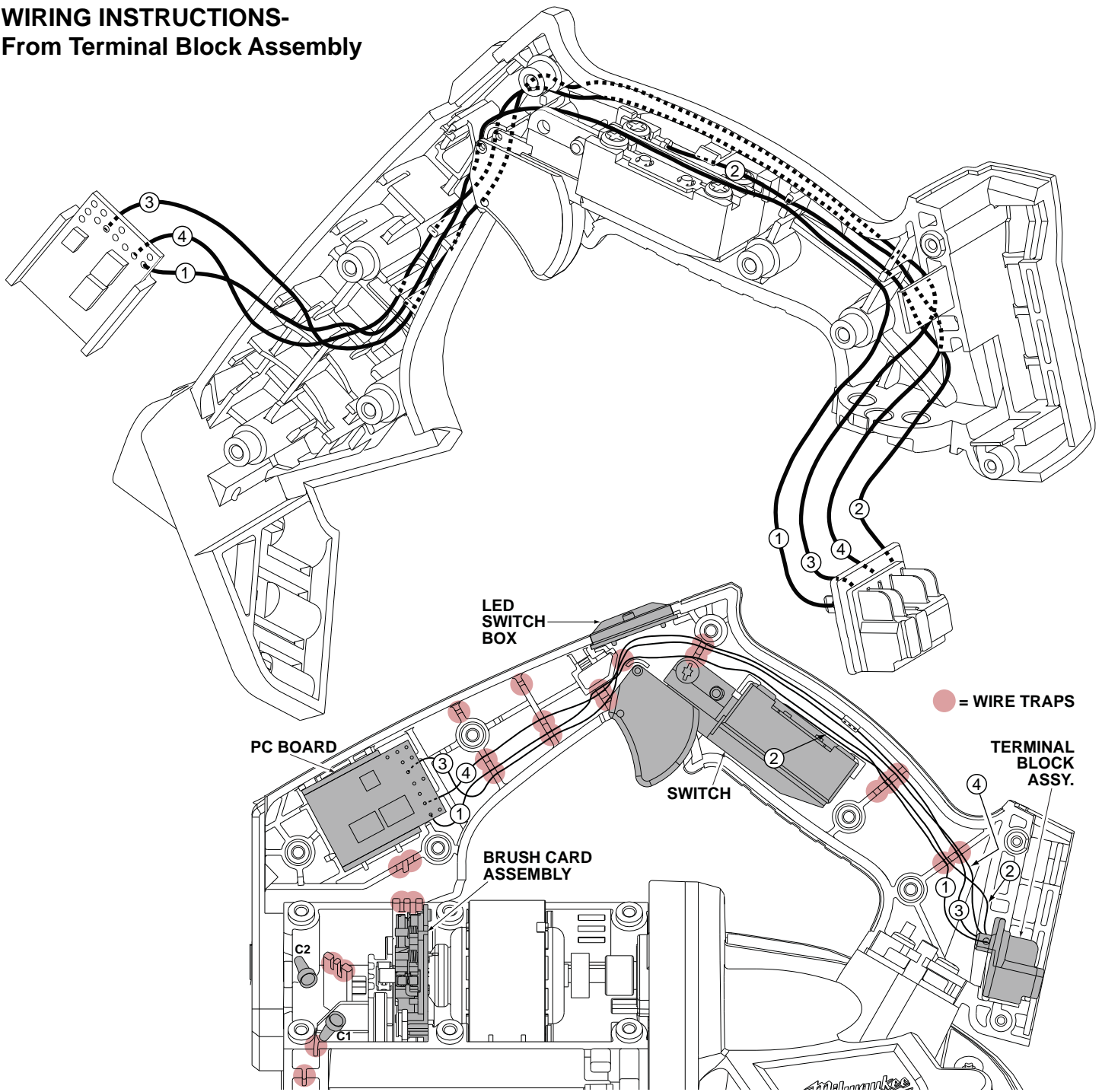

AS AN AID TO REASSEMBLY,  
TAKE NOTICE OF WIRE ROUTING AND  
POSITION IN WIRE GUIDES AND TRAPS  
WHILE DISMANTLING TOOL.

BE CAREFUL AND AVOID PINCHING  
WIRES BETWEEN HANDLE HALVES  
WHEN ASSEMBLING.

WIRING SPECIFICATIONS					
Wire No.	Wire Color	Origin or Gauge	Length	Terminals, Connectors and 1 or 2 End Wire Preparation	
1	Black	Electronics Kit	-----	Connects from Terminal Block Assembly to PCB.	
2	Red	Electronics Kit	-----	Connects from Terminal Block Assembly to Switch.	
3	Black	Electronics Kit	-----	Connects from Terminal Block Assembly to PCB.	
4	Pink	Electronics Kit	-----	Connects from Terminal Block Assembly to PCB.	
5	White	Electronics Kit	-----	Connects from LED Switch Box to PCB.	
6	Pink	Electronics Kit	-----	Connects from LED Switch Box to LED.	
7	Black	Electronics Kit	-----	Connects from LED Switch Box to PCB.	
8	Pink	Electronics Kit	-----	Connects from LED Switch Box to PCB.	
9	Black	Electronics Kit	-----	Connects from PCB to Wire #13 from Brush Card with C1.	
10	Red	Electronics Kit	-----	Connects from PCB to Wire #12 from Brush Card with C2.	
11	Black	Electronics Kit	-----	Connects from PCB to LED.	
12	Red	Brush Card Assy.	-----	Connects from Brush Card to Wire #10 from PCB with C2.	
13	Black	Brush Card Assy.	-----	Connects from Brush Card to Wire #9 from PCB with C1.	
14	Red	Electronics Kit	-----	Connects from PCB to Switch. (See detail on page 5).	
15	Black	Electronics Kit	-----	Connects from PCB to Switch. (See detail on page 5).	
16	Pink	Electronics Kit	-----	Connects from PCB to Switch. (See detail on page 5).	

# WIRING INSTRUCTIONS- To Switch

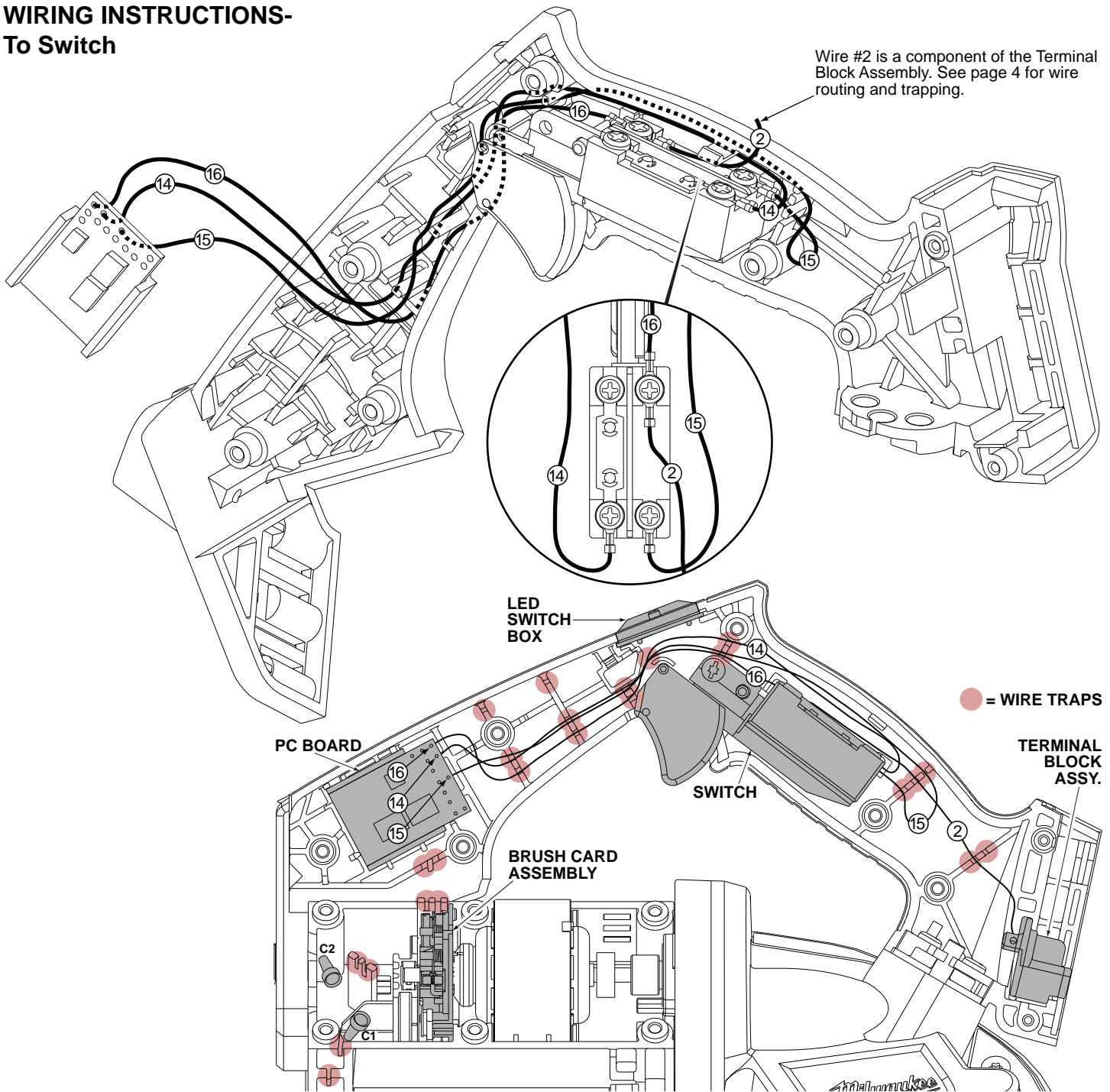

AS AN AID TO REASSEMBLY,  
TAKE NOTICE OF WIRE ROUTING AND  
POSITION IN WIRE GUIDES AND TRAPS  
WHILE DISMANTLING TOOL.

BE CAREFUL AND AVOID PINCHING  
WIRES BETWEEN HANDLE HALVES  
WHEN ASSEMBLING.

## WIRING SPECIFICATIONS

Wire No.	Wire Color	Origin or Gauge	Length	Terminals, Connectors and 1 or 2 End Wire Preparation
1	Black	Electronics Kit	-----	Connects from Terminal Block Assembly to PCB.
2	Red	Electronics Kit	-----	Connects from Terminal Block Assembly to Switch.
3	Black	Electronics Kit	-----	Connects from Terminal Block Assembly to PCB.
4	Pink	Electronics Kit	-----	Connects from Terminal Block Assembly to PCB.
5	White	Electronics Kit	-----	Connects from LED Switch Box to PCB.
6	Pink	Electronics Kit	-----	Connects from LED Switch Box to LED.
7	Black	Electronics Kit	-----	Connects from LED Switch Box to PCB.
8	Pink	Electronics Kit	-----	Connects from LED Switch Box to PCB.
9	Black	Electronics Kit	-----	Connects from PCB to Wire #13 from Brush Card with C1.
10	Red	Electronics Kit	-----	Connects from PCB to Wire #12 from Brush Card with C2.
11	Black	Electronics Kit	-----	Connects from PCB to LED.
12	Red	Brush Card Assy.	-----	Connects from Brush Card to Wire #10 from PCB with C2.
13	Black	Brush Card Assy.	-----	Connects from Brush Card to Wire #9 from PCB with C1.
14	Red	Electronics Kit	-----	Connects from PCB to Switch. (See detail on page 5).
15	Black	Electronics Kit	-----	Connects from PCB to Switch. (See detail on page 5).
16	Pink	Electronics Kit	-----	Connects from PCB to Switch. (See detail on page 5).

# WIRING INSTRUCTIONS- From PC Board and Brush Card Assembly

AS AN AID TO REASSEMBLY,  
TAKE NOTICE OF WIRE ROUTING AND  
POSITION IN WIRE GUIDES AND TRAPS  
WHILE DISMANTLING TOOL.

BE CAREFUL AND AVOID PINCHING  
WIRES BETWEEN HANDLE HALVES  
WHEN ASSEMBLING.

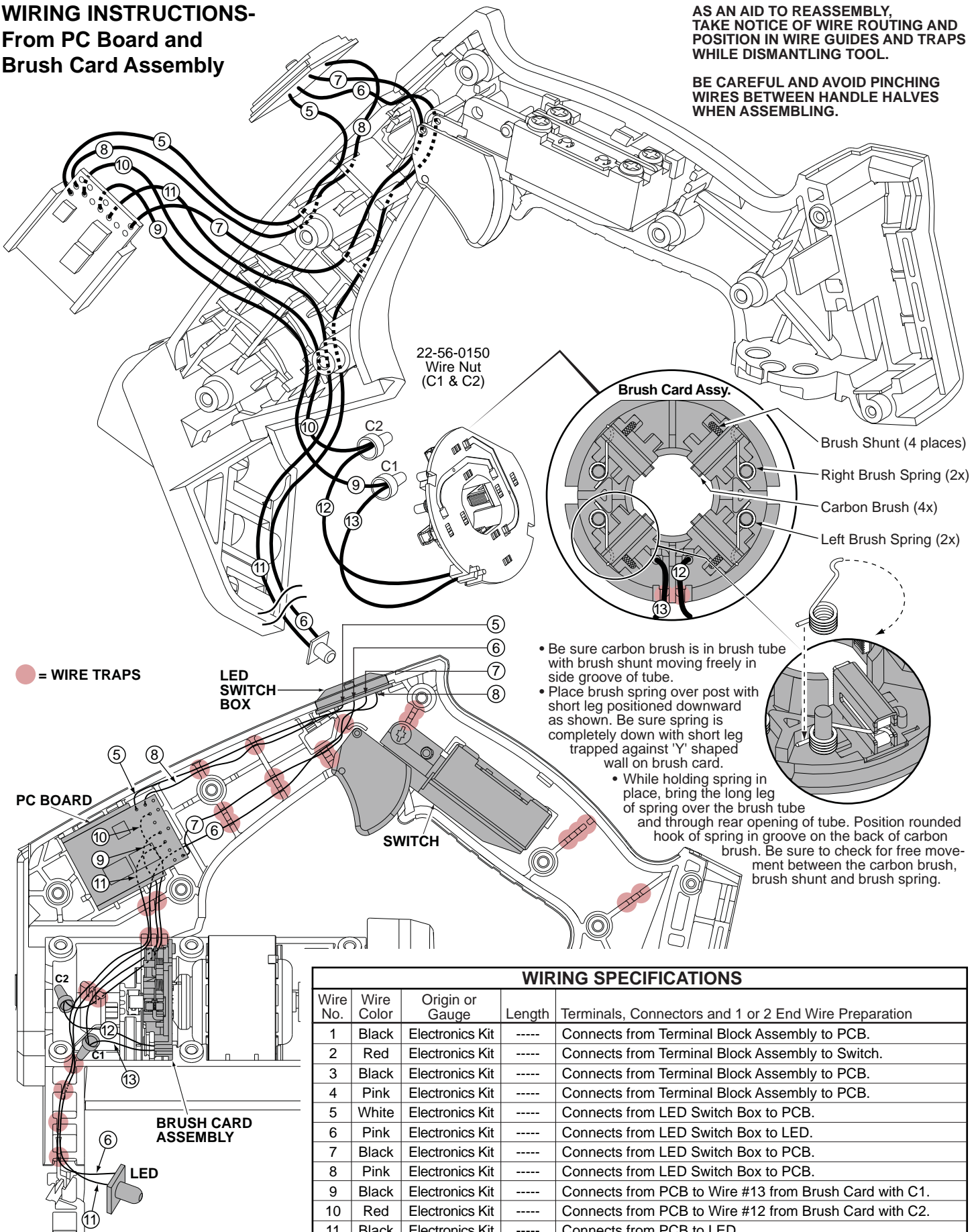

- Be sure carbon brush is in brush tube with brush shunt moving freely in side groove of tube.
- Place brush spring over post with short leg positioned downward as shown. Be sure spring is completely down with short leg trapped against 'Y' shaped wall on brush card.
- While holding spring in place, bring the long leg of spring over the brush tube and through rear opening of tube. Position rounded hook of spring in groove on the back of carbon brush. Be sure to check for free movement between the carbon brush, brush shunt and brush spring.

## WIRING SPECIFICATIONS

Wire No.	Wire Color	Origin or Gauge	Length	Terminals, Connectors and 1 or 2 End Wire Preparation
1	Black	Electronics Kit	-----	Connects from Terminal Block Assembly to PCB.
2	Red	Electronics Kit	-----	Connects from Terminal Block Assembly to Switch.
3	Black	Electronics Kit	-----	Connects from Terminal Block Assembly to PCB.
4	Pink	Electronics Kit	-----	Connects from Terminal Block Assembly to PCB.
5	White	Electronics Kit	-----	Connects from LED Switch Box to PCB.
6	Pink	Electronics Kit	-----	Connects from LED Switch Box to LED.
7	Black	Electronics Kit	-----	Connects from LED Switch Box to PCB.
8	Pink	Electronics Kit	-----	Connects from LED Switch Box to PCB.
9	Black	Electronics Kit	-----	Connects from PCB to Wire #13 from Brush Card with C1.
10	Red	Electronics Kit	-----	Connects from PCB to Wire #12 from Brush Card with C2.
11	Black	Electronics Kit	-----	Connects from PCB to LED.
12	Red	Brush Card Assy.	-----	Connects from Brush Card to Wire #10 from PCB with C2.
13	Black	Brush Card Assy.	-----	Connects from Brush Card to Wire #9 from PCB with C1.
14	Red	Electronics Kit	-----	Connects from PCB to Switch. (See detail on page 5).
15	Black	Electronics Kit	-----	Connects from PCB to Switch. (See detail on page 5).
16	Pink	Electronics Kit	-----	Connects from PCB to Switch. (See detail on page 5).

# WIRING INSTRUCTIONS-

All wire routings and trapping

AS AN AID TO REASSEMBLY, TAKE NOTICE OF WIRE ROUTING AND POSITION IN WIRE GUIDES AND TRAPS WHILE DISMANTLING TOOL.

BE CAREFUL AND AVOID PINCHING WIRES BETWEEN HANDLE HALVES WHEN ASSEMBLING.

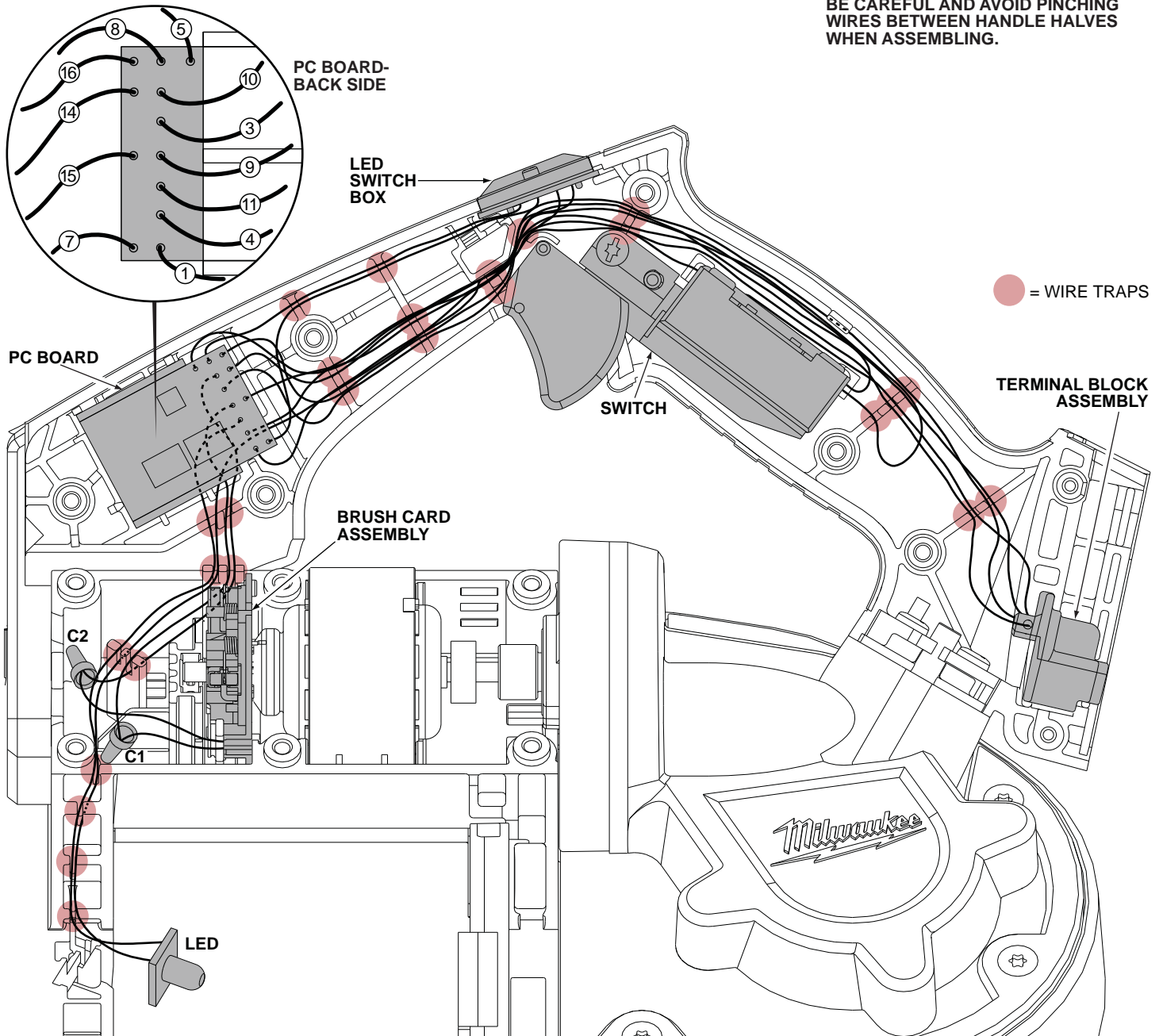

## WIRING SPECIFICATIONS

Wire No.	Wire Color	Origin or Gauge	Length	Terminals, Connectors and 1 or 2 End Wire Preparation
1	Black	Electronics Kit	-----	Connects from Terminal Block Assembly to PCB.
2	Red	Electronics Kit	-----	Connects from Terminal Block Assembly to Switch.
3	Black	Electronics Kit	-----	Connects from Terminal Block Assembly to PCB.
4	Pink	Electronics Kit	-----	Connects from Terminal Block Assembly to PCB.
5	White	Electronics Kit	-----	Connects from LED Switch Box to PCB.
6	Pink	Electronics Kit	-----	Connects from LED Switch Box to LED.
7	Black	Electronics Kit	-----	Connects from LED Switch Box to PCB.
8	Pink	Electronics Kit	-----	Connects from LED Switch Box to PCB.
9	Black	Electronics Kit	-----	Connects from PCB to Wire #13 from Brush Card with C1.
10	Red	Electronics Kit	-----	Connects from PCB to Wire #12 from Brush Card with C2.
11	Black	Electronics Kit	-----	Connects from PCB to LED.
12	Red	Brush Card Assy.	-----	Connects from Brush Card to Wire #10 from PCB with C2.
13	Black	Brush Card Assy.	-----	Connects from Brush Card to Wire #9 from PCB with C1.
14	Red	Electronics Kit	-----	Connects from PCB to Switch. (See detail on page 5).
15	Black	Electronics Kit	-----	Connects from PCB to Switch. (See detail on page 5).
16	Pink	Electronics Kit	-----	Connects from PCB to Switch. (See detail on page 5).