



SERVICE PARTS LIST

BULLETIN NO.
54-24-5362

SPECIFY CATALOG NO. AND SERIAL NO. WHEN ORDERING PARTS				REVISED BULLETIN	DATE
1" COMPACT SDS ROTARY HAMMER				54-24-5361	Mar. 2009
CATALOG NO.	5363-21	STARTING SERIAL NO.	B03C	WIRING INSTRUCTION	
				58-01-1280	

EXAMPLE:
Component Parts (Small #) Are Included
When Ordering The Assembly (Large #).

301	1207	308	306	201
	302	305	307	

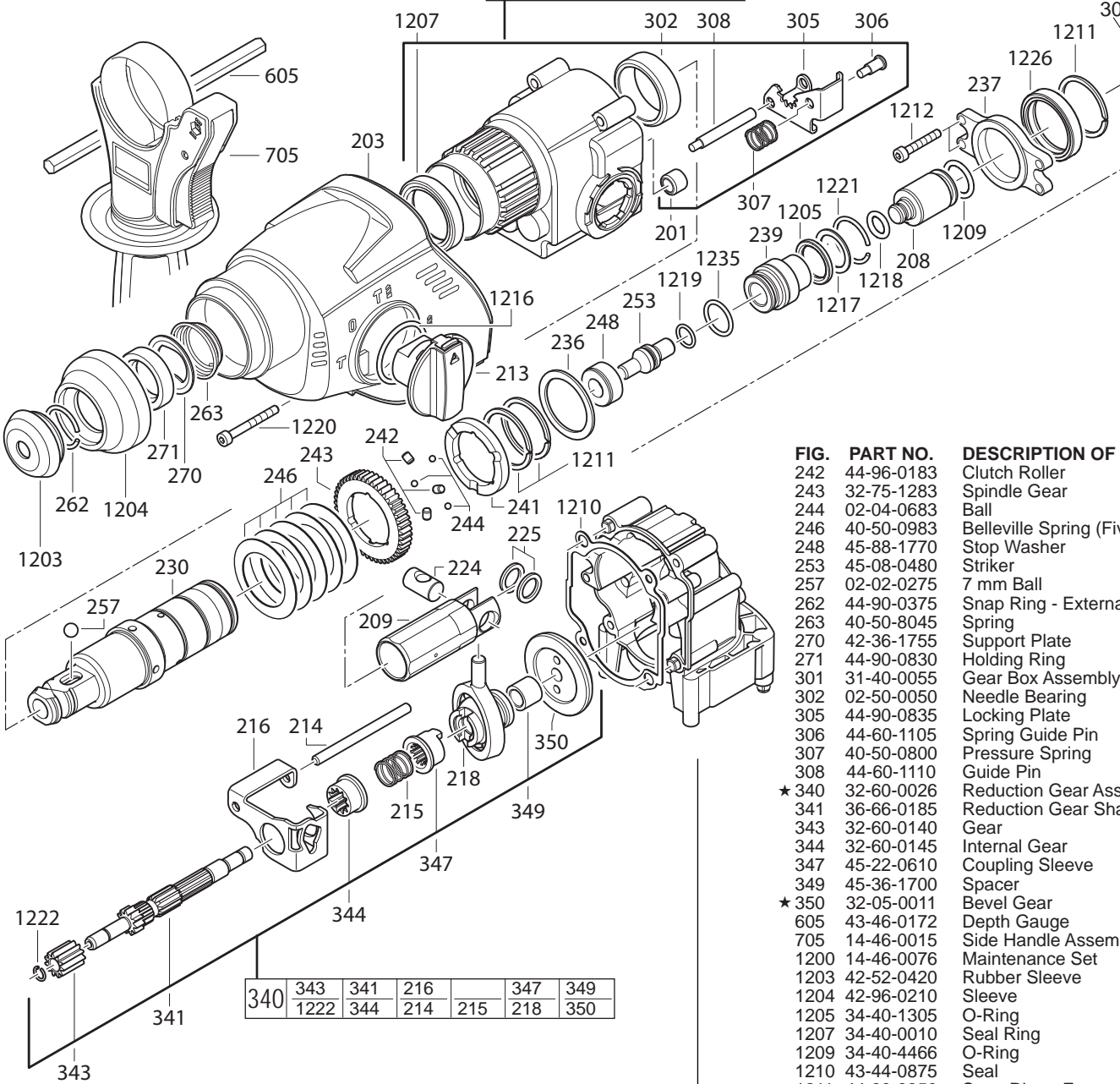

FIG.	PART NO.	DESCRIPTION OF PART	NO. REQ.
	242	44-96-0183 Clutch Roller	(3)
	243	32-75-1283 Spindle Gear	(1)
	244	02-04-0683 Ball	(3)
	246	40-50-0983 Belleville Spring (Five Required)	(5)
	248	45-88-1770 Stop Washer	(1)
	253	45-08-0480 Striker	(1)
	257	02-02-0275 7 mm Ball	(1)
	262	44-90-0375 Snap Ring - External	(1)
	263	40-50-8045 Spring	(1)
	270	42-36-1755 Support Plate	(1)
	271	44-90-0830 Holding Ring	(1)
	301	31-40-0055 Gear Box Assembly	(1)
	302	02-50-0050 Needle Bearing	(1)
	305	44-90-0835 Locking Plate	(1)
	306	44-60-1105 Spring Guide Pin	(1)
	307	40-50-0800 Pressure Spring	(1)
	308	44-60-1110 Guide Pin	(1)
	★ 340	32-60-0026 Reduction Gear Assy	(1)
	341	36-66-0185 Reduction Gear Shaft	(1)
	343	32-60-0140 Gear	(1)
	344	32-60-0145 Internal Gear	(1)
	347	45-22-0610 Coupling Sleeve	(1)
	349	45-36-1700 Spacer	(1)
	★ 350	32-05-0011 Bevel Gear	(1)
	605	43-46-0172 Depth Gauge	(1)
	705	14-46-0015 Side Handle Assembly	(1)
	1200	14-46-0076 Maintenance Set	(1)
	1203	42-52-0420 Rubber Sleeve	(1)
	1204	42-96-0210 Sleeve	(1)
	1205	34-40-1305 O-Ring	(1)
	1207	34-40-0010 Seal Ring	(1)
	1209	34-40-4466 O-Ring	(1)
	1210	43-44-0875 Seal	(1)
	1211	44-90-0350 Snap Ring - External	(3)
	1212	05-78-0041 M4 x 24 Thread Form Screw	(8)
	1216	34-40-1025 O-Ring	(1)
	1217	42-76-0830 Thrust Collar	(1)
	1218	34-40-4451 O-Ring	(1)
	1219	34-40-0130 O-Ring	(1)
	1220	05-78-0031 M4 x 38 Thread Form Screw	(4)
	1221	44-90-0183 Retaining Ring - Internal	(1)
	1222	34-40-0430 Spring Ring	(1)
	1226	44-90-0347 Damping Ring	(1)
	1235	34-40-0445 O-Ring	(1)
	30	48-55-0077 Molded Carrying Case, Optional	(1)

FIG.	PART NO.	DESCRIPTION OF PART	NO. REQ.
	201	02-50-2183 Needle Bearing	(1)
	203	34-40-0186 Gear Box Housing Cover	(1)
	208	45-56-0076 Ram	(1)
	209	44-62-0055 Cylinder	(1)
	213	44-10-0670 Switch Handle	(1)
	214	44-60-0756 Pin	(1)
	215	40-50-0883 Spring	(1)
	216	44-90-0500 Shift Ring	(1)
	218	36-92-0583 Wobble Plate	(1)
	224	44-60-0483 Wrist Pin	(1)
	225	45-88-0283 Washer	(2)
	230	32-75-0041 Spindle	(1)
	236	45-88-0485 Washer	(1)
	237	44-66-0085 Endplate Assembly	(1)
	239	45-22-0705 Sleeve	(1)
	241	42-70-0040 Clutch Disc	(1)

340	343	341	216	347	349
	1222	344	214	215	218

SEE PAGE 3 FOR IMPORTANT SERVICE NOTES

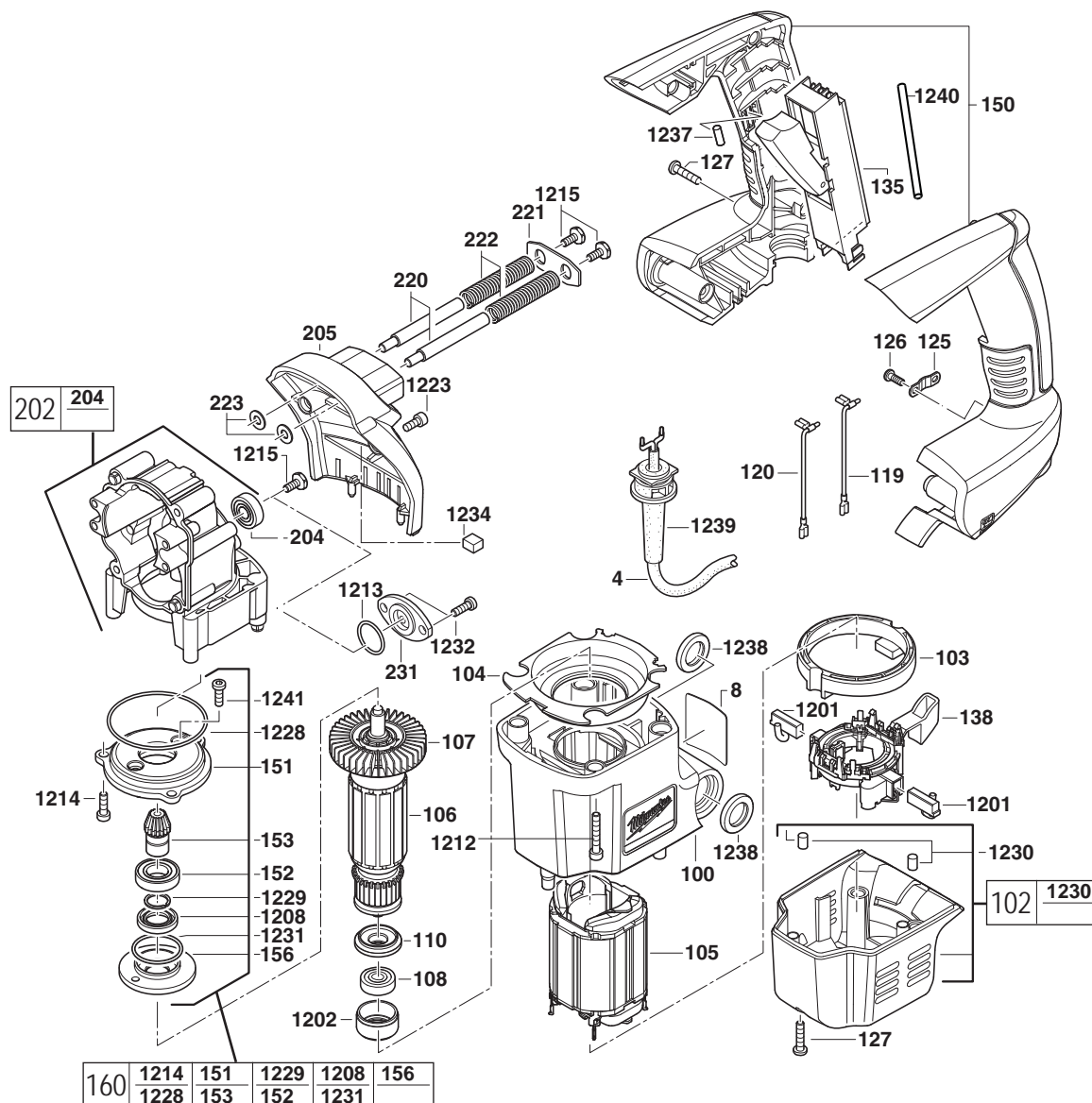

FIG.	PART NO.	DESCRIPTION OF PART	NO. REQ.	FIG.	PART NO.	DESCRIPTION OF PART	NO. REQ.
4	22-64-1622	Cord Set	(1)	205	31-15-0760	Gearbox Cover	(1)
8	12-20-5363	Service Nameplate	(1)	220	44-60-0205	Guide Pin	(2)
100	31-40-5363	Motor Housing	(1)	221	44-90-0070	Latch Plate	(1)
102	31-15-0060	Cover Assembly	(1)	222	40-50-0505	Spring	(2)
103	22-22-0070	Brush Carrier	(1)	223	45-88-0875	Washer	(2)
104	31-05-0095	Air Deflector Ring	(1)	231	42-92-1520	Bearing Cover	(1)
105	18-07-0015	Service Field	(1)	1200	14-46-0076	Maintenance Set	(1)
106	16-07-0015	Service Armature	(1)	1201	22-18-0010	Carbon Brush Set	(1)
107	22-84-0040	Fan	(1)	1202	42-96-0205	Rubber Sleeve	(1)
108	02-04-1801	Ball Bearing	(1)	1208	45-06-0095	Seal Ring	(1)
110	45-88-9000	Insulating Disc	(1)	1213	34-40-0083	O-Ring	(1)
119	23-94-0155	Wire	(1)	1214	05-78-0051	M4 x 12 Thread Form Screw	(3)
120	23-94-0175	Wire	(1)	1215	05-74-0220	Screw	(3)
125	31-17-0240	Cord Clamp	(1)	1223	05-78-0051	M4 x 12 Thread Form Screw	(2)
126	05-78-0720	Screw	(2)	1228	34-40-0435	O-Ring	(1)
127	05-78-0715	Screw	(7)	1229	45-88-1775	Spring Ring	(1)
135	23-66-0405	Switch	(1)	1230	45-30-0055	Slug	(2)
138	22-22-0075	Brush Carrier	(1)	1231	34-40-0440	O-Ring	(1)
150	14-38-0115	Handle Assembly	(1)	1232	05-74-0460	Cap Screw	(2)
151	44-66-0540	Bearing End Plate	(1)	1234	43-84-0443	Felt	(1)
152	02-04-0090	Ball Bearing	(1)	1237	45-30-0215	Vinyl Slug	(1)
★ 153	32-60-0016	Pinion	(1)	1238	34-40-0063	O-Ring Motor Housing	(2)
156	42-92-0165	Bearing Cover	(1)	1239	44-76-0075	Cord Protector	(1)
★ 160	44-66-1147	Bearing End Plate Assembly	(1)	1240	45-30-0075	Rubber Slug	(1)
202	31-15-0106	Gear Box	(1)	1241	05-74-0715	Screw	(2)
204	02-04-0056	Ball Bearing	(1)	49-08-5350	Type "P" Grease (100 g)		(1)
				49-08-4255	Type "Q" Grease (45 g)		(1)

Service Kit 14-46-0076 Contains:

Cat. No.	Description	Qty.			
22-18-0010	Carbon Brush Set	(1)	05-78-0031	M4 x 38 Thread Form Screw	(4)
42-96-0205	Rubber Sleeve	(1)	44-90-0183	Retaining Ring - Internal	(1)
42-52-0420	Rubber Sleeve	(1)	34-40-0430	Spring Ring	(1)
42-96-0210	Sleeve	(1)	05-78-0051	M4 x 12 Thread Form Screw	(5)
34-40-1305	O-Ring	(1)	44-90-0347	Damping Ring	(1)
34-40-0010	Seal Ring	(1)	34-40-0435	O-Ring	(1)
45-06-0095	Seal Ring	(1)	45-88-1775	Spring Ring	(1)
34-40-4466	O-Ring	(1)	45-30-0055	Slug	(2)
43-44-0875	Seal	(1)	34-40-0440	O-Ring	(1)
44-90-0350	Snap Ring - External	(3)	05-74-0460	Cap Screw	(2)
05-78-0041	M4 x 24 Thread Form Screw	(8)	43-84-0443	Felt	(1)
34-40-0083	O-Ring	(1)	34-40-0445	O-Ring	(1)
05-74-0715	Socket Head Screw - Plast.	(2)	45-30-0215	Vinyl Slug	(1)
05-74-0220	Screw	(3)	34-40-0063	O-Ring Motor Housing	(2)
34-40-1025	O-Ring	(1)	49-08-5350	Type "P" Grease (100 g)	(1)
42-76-0830	Thrust Collar	(1)	49-08-4255	Type "Q" Grease (45 g)	(1)
34-40-4451	O-Ring	(1)	44-76-0075	Cord Protector	(1)
34-40-0130	O-Ring	(1)	45-30-0075	Rubber Slug	(1)

Service Notes:

Disassembly:

- 220, 1215 Remove screw (s) (1215) from guide bolts (220) evenly to release spring tension.
- 202, 220 Remove guide bolts (220) from gearbox (202) using a 4mm hex key.
- 203, 213 When, removing shift lever (213) from gear case cover (203) follow instructions listed on service bulletin. [see fig. 1]
- 202, 203, 301 Release locking tabs on gearbox cover (203) when removing from gearbox assembly (301 and 202). [see fig. 3]
- 301, 308 Remove guide bolt (308) from gearbox (301) using a 3mm hex key
- 106, 152, 153 Remove armature pinion (153) from armature (106) using Special Service Fixture 61-10-0025.
Note: Place separator plates 61-10-0011 under ball bearing (152) as illustrated in fig. 5.
- 230, 243, 246, 1211 To remove retaining ring (1211) from spindle (230) use service fixture 61-30-0290.
Note: Spindle gear / clutch gear (243) must be compressed against Belleville spring washers (246) before retainer can be removed with a pair of retaining ring pliers. (see fig.8)
- 105, 138 To remove brush carrier (138) from field (105) you must lift brush carrier locking tabs at the front and back of the field board on both sides while applying a light upward force on the carrier.

Reassembly:

- 105, 138 To reassemble brush carrier (138) onto field (105) you must align male prongs of carrier with female mag-mate terminals on the field and push brush carrier down until locking tabs on the brush carrier lock onto the field board.
- 248, 253 Small diameter end of striker (253) must face stop washer (248) in assembly.
- 230, 248 Chamfer side of stop washer (248) must face front of spindle (230).
- 202, 237 Raised bosses on end plate assembly (237) must face gearbox (202) in assembly
- 203, 213 When, reinstalling shift lever (213) into gearcase cover (203) follow instructions shown in fig. 2.
- 220, 306, 308 Apply Blue Loctite ® METCo part # 44-22-0090 to fasteners listed if removed and being reinstalled.
1212, 1214, 1215 New fasteners in service kit will not require Loctite®.
1220, 1223, 1232
- 262, 271 Taper of holding ring (271) must face spring ring (262) in assembly.
- 263, 270 Wide portion of conical spring (263) must face plate (270).
- 341, 349, 350 When reassembling bevel gear (350) onto reduction gear shaft (341) a .001 to .002 clearance must be maintained between bevel gear (350) and spacer (349). [see fig.4]
- 152, 1208 Flared edge of seal (1208) must face ball bearing (152) in assembly.
- 246 Reassemble, Belleville Spring washers as illustrated in fig. 7.
- 106, 107 When replacing a fan (107) on armature assembly (106), refer to illustration shown in fig. 6 for press dimensions.
- 341, 1222 Install a new spring ring retainer (1222) if removed from reduction gear shaft (341).

NOTE: Check the clutch torque. Clutch must slip at 17 to 26 ft. lbs. at the spindle, checked clockwise as viewed from the front of the tool. Selector knob must be set to the hammer only setting.

Lubrication

Type "Q" Grease, No. 49-08-4255 (4931 6243 75)

Coat with a total of 1/4 oz.

Type "P" Grease, No. 49-08-5350 (4931 3757 90)

Coat with a total of 1-3/4 oz.

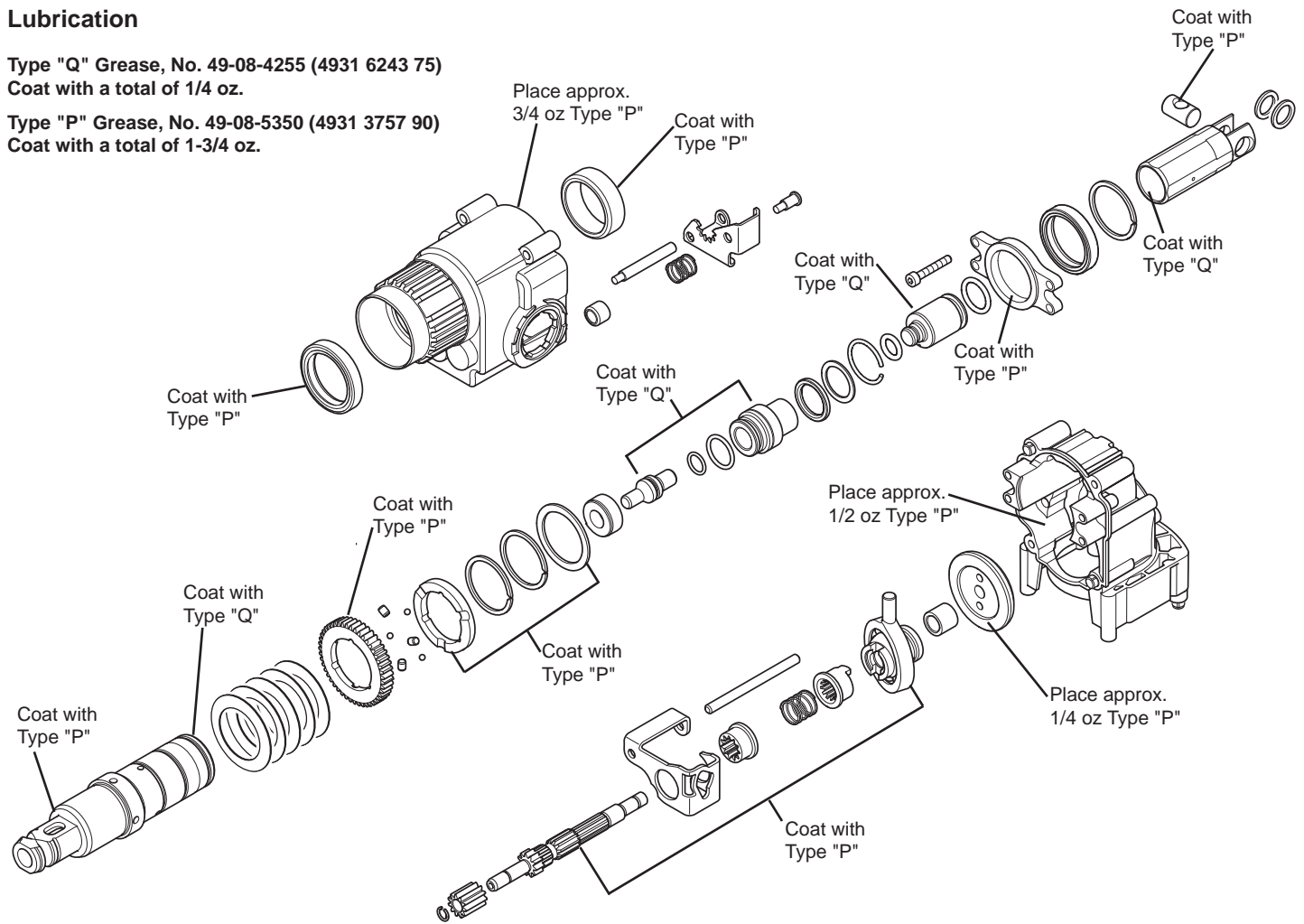

Torque Specifications

Screws in plastic, 15 in. lbs.

Screws in metal, 22 in. lbs. Use Blue Loctite® 242, Cat. No. 44-22-0090

Removing the shift lever

- 1 Bring the shift lever (2) into the Drill-Only position (Illustration A).
- 2 Press in and hold the locking device (3) (Illustration A) and turn the shift lever past the drill icon (Illustration B) until the shift lever (2) can be pulled from the housing.
- 3 Remove the O-ring (1).

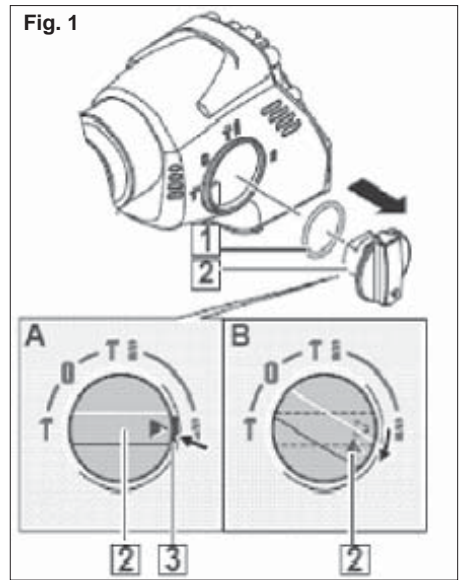

Installing the shift lever

- 1 Lightly grease the O-ring (1) and install it into the Shift Lever (2).
- 2 Position the triangle located on the shift lever to the Hammer / Drill icon and insert it into the gearcase (Illustration A). Press the locking device and turn clockwise (Illustration B) until the shift lever (2) engages audibly. After that, turn it back to the required position (C) and release the locking device.

