



# SERVICE PARTS LIST

**BULLETIN NO.**  
**54-24-5361**

SPECIFY CATALOG NO. AND SERIAL NO. WHEN ORDERING PARTS				REVISED BULLETIN	DATE
<b>1" COMPACT SDS ROTARY HAMMER</b>				54-24-5360	Dec. 2008
CATALOG NO.	<b>5363-21</b>	STARTING SERIAL NO.	<b>B03B</b>	WIRING INSTRUCTION <b>58-01-1280</b>	

**EXAMPLE:**  
Component Parts (Small #) Are Included  
When Ordering The Assembly (Large #).

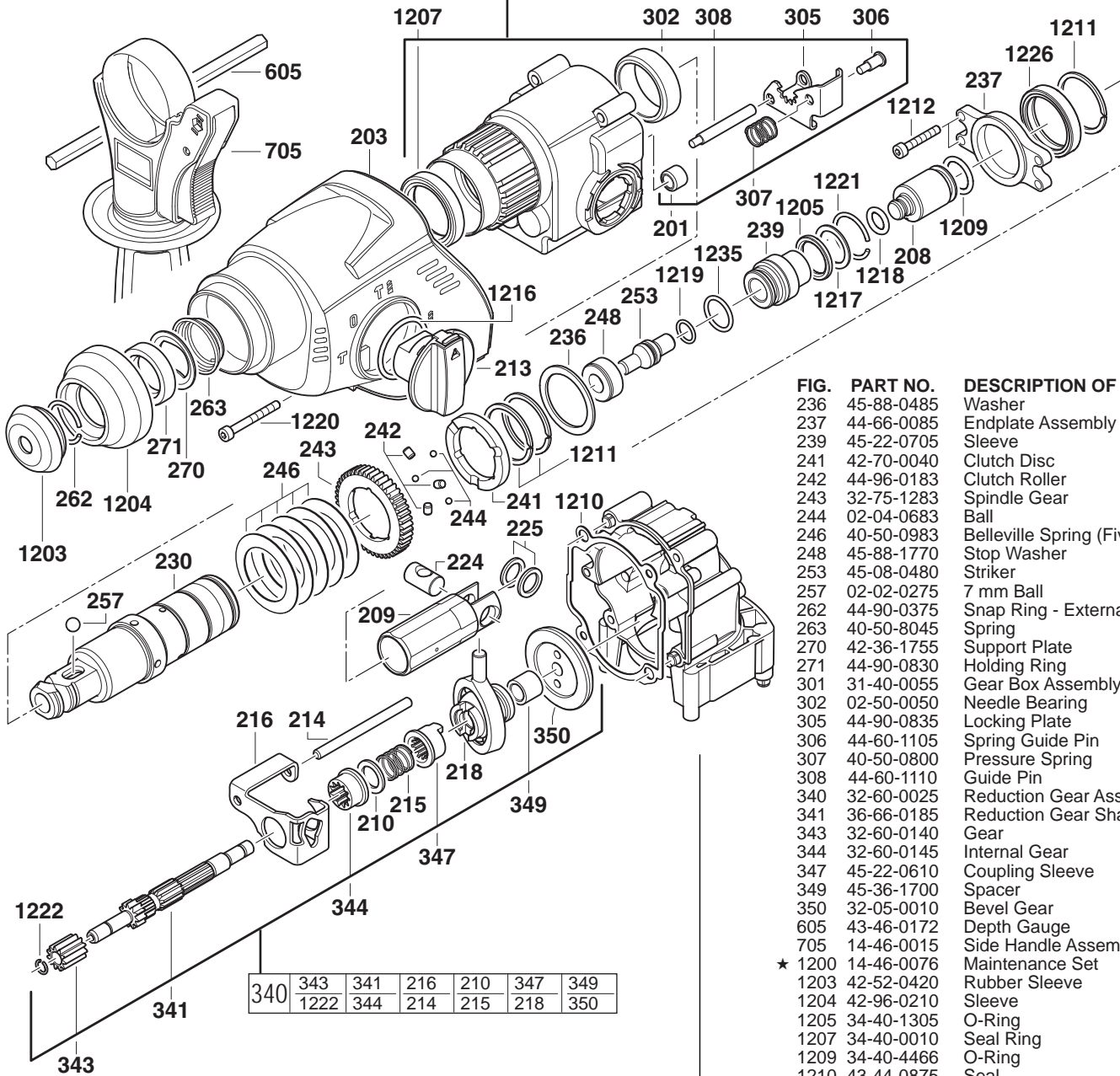

340	343	341	216	210	347	349
	1222	344	214	215	218	350

301	1207	308	306	201
	302	305	307	

FIG.	PART NO.	DESCRIPTION OF PART	NO. REQ.
	236	Washer	(1)
	237	Endplate Assembly	(1)
	239	Sleeve	(1)
	241	Clutch Disc	(1)
	242	Clutch Roller	(3)
	243	Spindle Gear	(1)
	244	Ball	(3)
	246	Belleville Spring (Five Required)	(5)
	248	Stop Washer	(1)
	253	Striker	(1)
	257	7 mm Ball	(1)
	262	Snap Ring - External	(1)
	263	Spring	(1)
	270	Support Plate	(1)
	271	Holding Ring	(1)
	301	Gear Box Assembly	(1)
	302	Needle Bearing	(1)
	305	Locking Plate	(1)
	306	Spring Guide Pin	(1)
	307	Pressure Spring	(1)
	308	Guide Pin	(1)
	340	Reduction Gear Assy	(1)
	341	Reduction Gear Shaft	(1)
	343	Gear	(1)
	344	Internal Gear	(1)
	347	Coupling Sleeve	(1)
	349	Spacer	(1)
	350	Bevel Gear	(1)
	605	Depth Gauge	(1)
	705	Side Handle Assembly	(1)
★	1200	Maintenance Set	(1)
	1203	Rubber Sleeve	(1)
	1204	Sleeve	(1)
	1205	O-Ring	(1)
	1207	Seal Ring	(1)
	1209	O-Ring	(1)
	1210	Seal	(1)
	1211	Snap Ring - External	(3)
★	1212	M4 x 24 Thread Form Screw	(8)
	1216	O-Ring	(1)
	1217	Thrust Collar	(1)
	1218	O-Ring	(1)
	1219	O-Ring	(1)
★	1220	M4 x 38 Thread Form Screw	(4)
	1221	Retaining Ring - Internal	(1)
	1222	Spring Ring	(1)
	1226	Damping Ring	(1)
	1235	O-Ring	(1)

FIG.	PART NO.	DESCRIPTION OF PART	NO. REQ.
	201	Needle Bearing	(1)
	203	Gear Box Housing Cover	(1)
	208	Ram	(1)
	209	Cylinder	(1)
	210	Disc	(1)
	213	Switch Handle	(1)
	214	Pin	(1)
	215	Spring	(1)
	216	Shift Ring	(1)
	218	Wobble Plate	(1)
	224	Wrist Pin	(1)
	225	Washer	(2)
	230	Spindle	(1)

**SEE PAGE 3 FOR IMPORTANT SERVICE NOTES**

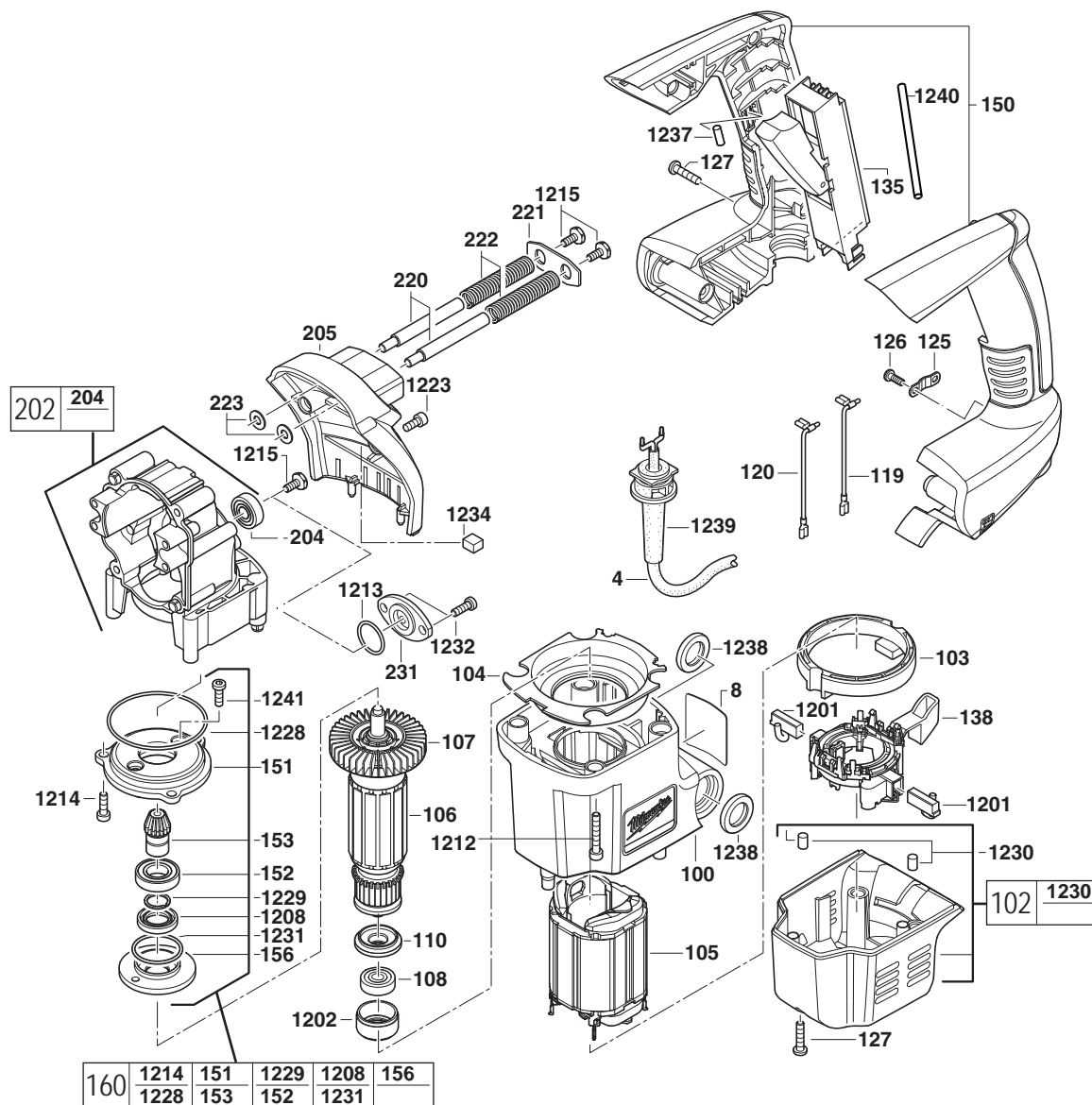

160	1214	151	1229	1208	156
	1228	153	152	1231	

FIG.	PART NO.	DESCRIPTION OF PART	NO. REQ.
4	22-64-1622	Cord Set	(1)
8	12-20-5363	Service Nameplate	(1)
100	31-40-5363	Motor Housing	(1)
102	31-15-0060	Cover Assembly	(1)
103	22-22-0070	Brush Carrier	(1)
104	31-05-0095	Air Deflector Ring	(1)
105	18-07-0015	Service Field	(1)
106	16-07-0015	Service Armature	(1)
107	22-84-0040	Fan	(1)
108	02-04-1801	Ball Bearing	(1)
110	45-88-9000	Insulating Disc	(1)
119	23-94-0155	Wire	(1)
120	23-94-0175	Wire	(1)
125	31-17-0240	Cord Clamp	(1)
126	05-78-0720	Screw	(2)
127	05-78-0715	Screw	(7)
135	23-66-0405	Switch	(1)
138	22-22-0075	Brush Carrier	(1)
150	14-38-0115	Handle Assembly	(1)
151	44-66-0540	Bearing End Plate	(1)
152	02-04-0090	Ball Bearing	(1)
153	32-60-0015	Pinion	(1)
156	42-92-0165	Bearing Cover	(1)
160	44-66-1146	Bearing End Plate Assembly	(1)
★ 202	31-15-0106	Gear Box	(1)
204	02-04-0056	Ball Bearing	(1)

FIG.	PART NO.	DESCRIPTION OF PART	NO. REQ.
205	31-15-0760	Gearbox Cover	(1)
220	44-60-0205	Guide Pin	(2)
221	44-90-0070	Latch Plate	(1)
222	40-50-0505	Spring	(2)
223	45-88-0875	Washer	(2)
231	42-92-1520	Bearing Cover	(1)
★ 1200	14-46-0076	Maintenance Set	(1)
1201	22-18-0010	Carbon Brush Set	(1)
1202	42-96-0205	Rubber Sleeve	(1)
1208	45-06-0095	Seal Ring	(1)
1213	34-40-0083	O-Ring	(1)
★ 1214	05-78-0051	M4 x 12 Thread Form Screw	(3)
1215	05-74-0220	Screw	(3)
★ 1223	05-78-0051	M4 x 12 Thread Form Screw	(2)
1228	34-40-0435	O-Ring	(1)
1229	45-88-1775	Spring Ring	(1)
1230	45-30-0055	Slug	(2)
1231	34-40-0440	O-Ring	(1)
1232	05-74-0460	Cap Screw	(2)
1234	43-84-0443	Felt	(1)
1237	45-30-0215	Vinyl Slug	(1)
1238	34-40-0063	O-Ring Motor Housing	(2)
1239	44-76-0075	Cord Protector	(1)
1240	45-30-0075	Rubber Slug	(1)
★ 1241	05-74-0715	Screw	(2)
★	48-55-0077	Molded Carrying Case (Not Shown)	(1)
	49-08-5350	Type "P" Grease (100 g)	(1)
	49-08-4255	Type "Q" Grease (45 g)	(1)

**Service Kit 14-46-0076 Contains:**

Cat. No.	Description	Qty.			
22-18-0010	Carbon Brush Set	(1)	05-78-0031	M4 x 38 Thread Form Screw	(4)
42-96-0205	Rubber Sleeve	(1)	44-90-0183	Retaining Ring - Internal	(1)
42-52-0420	Rubber Sleeve	(1)	34-40-0430	Spring Ring	(1)
42-96-0210	Sleeve	(1)	05-78-0051	M4 x 12 Thread Form Screw	(5)
34-40-1305	O-Ring	(1)	44-90-0347	Damping Ring	(1)
34-40-0010	Seal Ring	(1)	34-40-0435	O-Ring	(1)
45-06-0095	Seal Ring	(1)	45-88-1775	Spring Ring	(1)
34-40-4466	O-Ring	(1)	45-30-0055	Slug	(2)
43-44-0875	Seal	(1)	34-40-0440	O-Ring	(1)
44-90-0350	Snap Ring - External	(3)	05-74-0460	Cap Screw	(2)
05-78-0041	M4 x 24 Thread Form Screw	(8)	43-84-0443	Felt	(1)
34-40-0083	O-Ring	(1)	34-40-0445	O-Ring	(1)
05-74-0715	Socket Head Screw - Plast.	(2)	45-30-0215	Vinyl Slug	(1)
05-74-0220	Screw	(3)	34-40-0063	O-Ring Motor Housing	(2)
34-40-1025	O-Ring	(1)	49-08-5350	Type "P" Grease (100 g)	(1)
42-76-0830	Thrust Collar	(1)	49-08-4255	Type "Q" Grease (45 g)	(1)
34-40-4451	O-Ring	(1)	44-76-0075	Cord Protector	(1)
34-40-0130	O-Ring	(1)	45-30-0075	Rubber Slug	(1)

**Service Notes:**

**Disassembly:**

- 220, 1215 Remove screw (s) (1215) from guide bolts (220) evenly to release spring tension.
- 202, 220 Remove guide bolts (220) from gearbox (202) using a 4mm hex key.
- 203, 213 When, removing shift lever (213) from gear case cover (203) follow instructions listed on service bulletin. [see fig. 1]
- 202, 203, 301 Release locking tabs on gearbox cover (203) when removing from gearbox assembly (301 and 202). [see fig. 3]
- 301, 308 Remove guide bolt (308) from gearbox (301) using a 3mm hex key
- 106, 152, 153 Remove armature pinion (153) from armature (106) using Special Service Fixture 61-10-0025.  
Note: Place separator plates 61-10-0011 under ball bearing (152) as illustrated in fig. 5.
- 230, 243, 246, 1211 To remove retaining ring (1211) from spindle (230) use service fixture 61-30-0290.  
Note: Spindle gear / clutch gear (243) must be compressed against Belleville spring washers (246) before retainer can be removed with a pair of retaining ring pliers. (see fig.8)
- 105, 138 To remove brush carrier (138) from field (105) you must lift brush carrier locking tabs at the front and back of the field board on both sides while applying a light upward force on the carrier.

**Reassembly:**

- 105, 138 To reassemble brush carrier (138) onto field (105) you must align male prongs of carrier with female mag-mate terminals on the field and push brush carrier down until locking tabs on the brush carrier lock onto the field board.
- 248, 253 Small diameter end of striker (253) must face stop washer (248) in assembly.
- 230, 248 Chamfer side of stop washer (248) must face front of spindle (230).
- 202, 237 Raised bosses on end plate assembly (237) must face gearbox (202) in assembly
- 203, 213 When, reinstalling shift lever (213) into gearcase cover (203) follow instructions shown in fig. 2.
- 220, 306, 308 Apply Blue Loctite ® METCo part # 44-22-0090 to fasteners listed if removed and being reinstalled.  
1212, 1214, 1215 New fasteners in service kit will not require Loctite®.  
1220, 1223, 1232
- 262, 271 Taper of holding ring (271) must face spring ring (262) in assembly.
- 263, 270 Wide portion of conical spring (263) must face plate (270).
- 341, 349,350 When reassembling bevel gear (350) onto reduction gear shaft (341) a .001 to .002 clearance must be maintain between bevel gear (350) and spacer (349).[see fig.4]
- 152, 1208 Flared edge of seal (1208) must face ball bearing (152) in assembly.
- 246 Reassemble, Belleville Spring washers as illustrated in fig. 7.
- 106, 107 When replacing a fan (107) on armature assembly (106), refer to illustration shown in fig. 6 for press dimensions.
- 341, 1222 Install a new spring ring retainer (1222) if removed from reduction gear shaft (341).

**NOTE: Check the clutch torque. Clutch must slip at 17 to 26 ft. lbs. at the spindle, checked clockwise as viewed from the front of the tool. Selector knob must be set to the hammer only setting.**

## Lubrication

**Type "Q" Grease, No. 49-08-4255 (4931 6243 75)**

**Coat with a total of 1/4 oz.**

**Type "P" Grease, No. 49-08-5350 (4931 3757 90)**

**Coat with a total of 1-3/4 oz.**

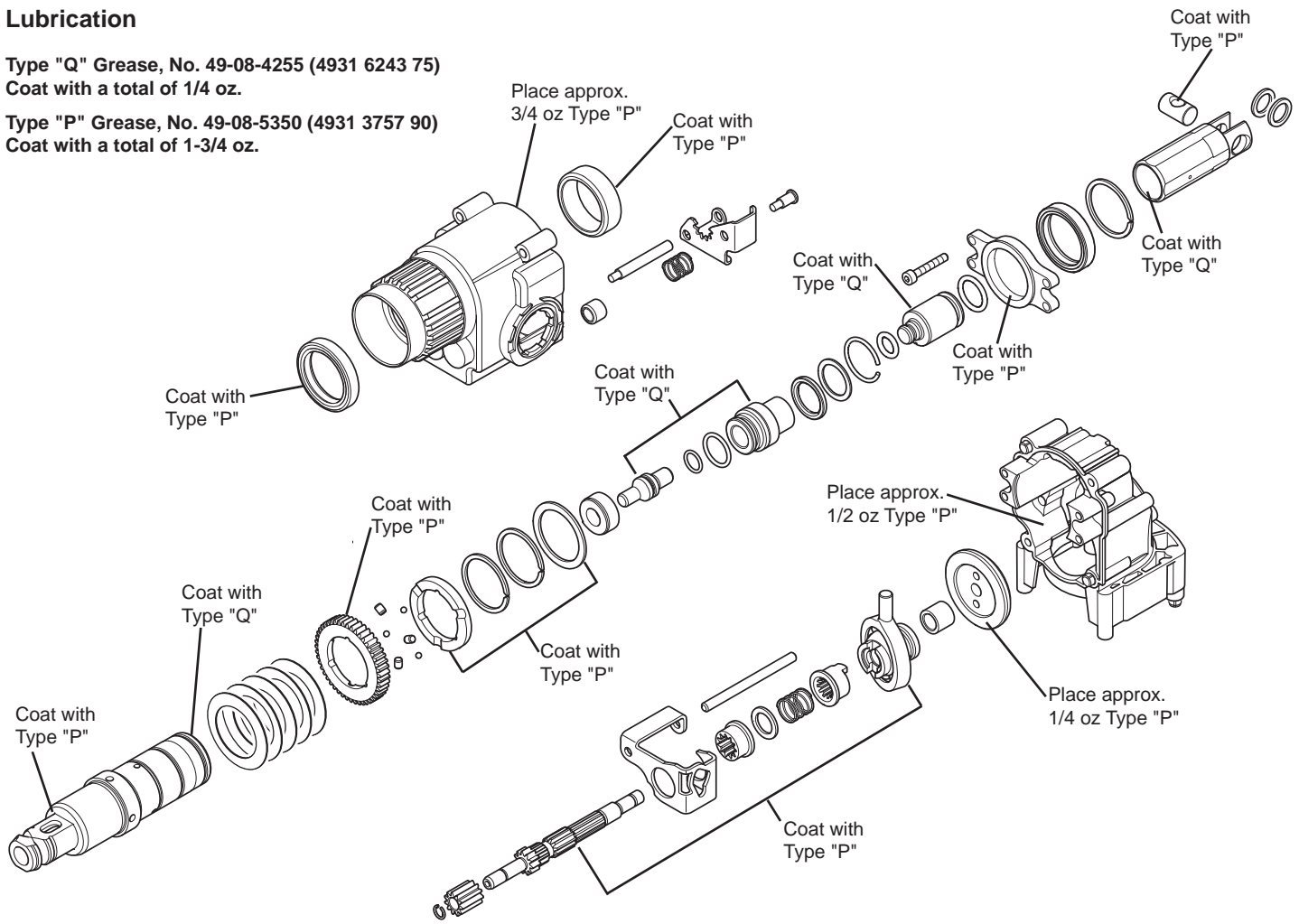

## Torque Specifications

**Screws in plastic, 15 in. lbs.**

**Screws in metal, 22 in. lbs. Use Blue Loctite® 242, Cat. No. 44-22-0090**

**Removing the shift lever**

- 1 Bring the shift lever (2) into the Drill-Only position (Illustration A).
- 2 Press in and hold the locking device (3) (Illustration A) and turn the shift lever past the drill icon (Illustration B) until the shift lever (2) can be pulled from the housing.
- 3 Remove the O-ring (1).

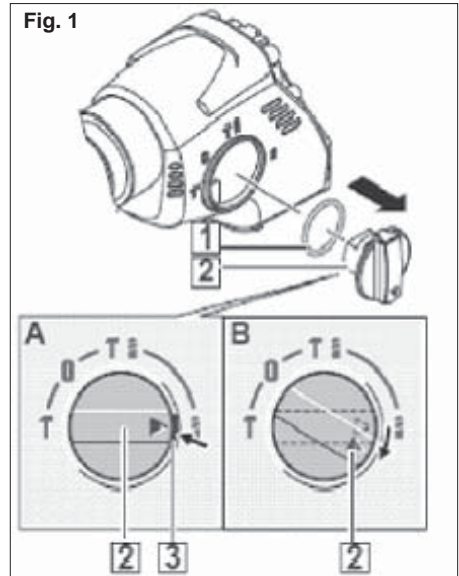
**Installing the shift lever**

- 1 Lightly grease the O-ring (1) and install it into the Shift Lever (2).
- 2 Position the triangle located on the shift lever to the Hammer / Drill icon and insert it into the gearcase (Illustration A). Press the locking device and turn clockwise (Illustration B) until the shift lever (2) engages audibly. After that, turn it back to the required position (C) and release the locking device.

