



SERVICE PARTS LIST

BULLETIN NO.
55-40-7011

SPECIFY CATALOG NO. AND SERIAL NO. WHEN ORDERING PARTS		REVISED BULLETIN	DATE
CORDLESS SAWZALL®		55-40-7010	Aug. 2006
CATALOG NO.	0719-50	STARTING SERIAL NO.	A56B
		WIRING INSTRUCTION SEE REVERSE SIDE	

NOTES:
Seal side of bearing (2) to face armature (15).

Stamped arrows (>>) on field casing (16) to face armature fan (11).

Concave side of connector block cover (23) to face connector block (19).

EXAMPLE:
Component Parts (Small #) Are Included When Ordering The Assembly (Large #).

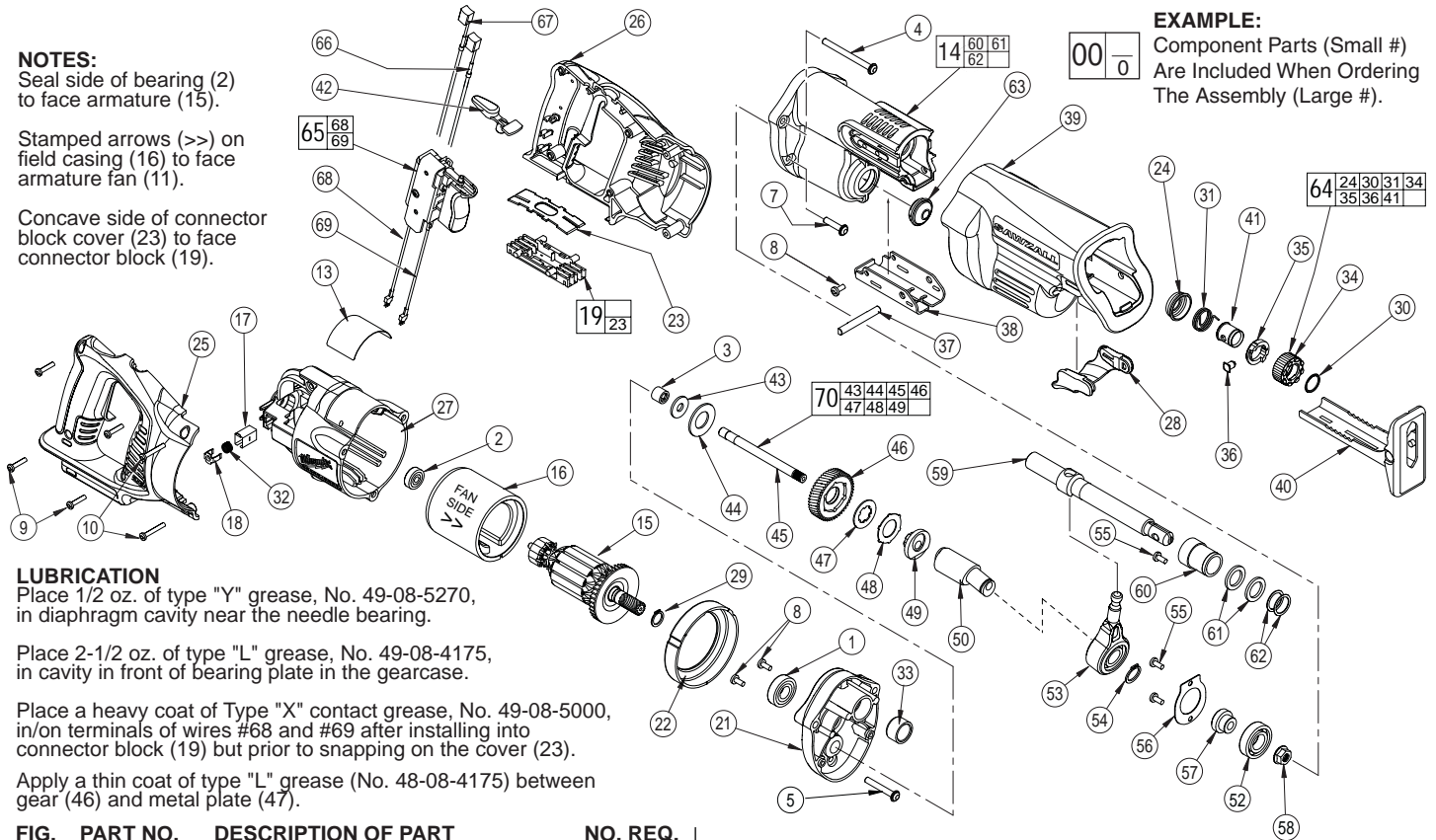

LUBRICATION

Place 1/2 oz. of type "Y" grease, No. 49-08-5270, in diaphragm cavity near the needle bearing.

Place 2-1/2 oz. of type "L" grease, No. 49-08-4175, in cavity in front of bearing plate in the gearcase.

Place a heavy coat of Type "X" contact grease, No. 49-08-5000, in/on terminals of wires #68 and #69 after installing into connector block (19) but prior to snapping on the cover (23).

Apply a thin coat of type "L" grease (No. 48-08-4175) between gear (46) and metal plate (47).

★ = Part number change from previous service parts list.

FIG.	PART NO.	DESCRIPTION OF PART	NO. REQ.
1	02-04-0719	Ball Bearing	(1)
2	02-04-5130	Ball Bearing	(1)
3	02-50-2150	Needle Bearing	(1)
4	05-88-0302	K50 x 60mm Washer Hd. PT Screw	(2)
5	05-88-8309	K50 x 35mm Washer Hd. PT Screw	(1)
7	06-82-5363	8-32 x 1 Washer Hd. Taptite T-20 Screw	(2)
8	06-82-7253	8-32 x .38 Taptite T-20 Screw	(3)
9	06-82-7261	6-19 x .687 Slotted Plastite T-15 Screw	(4)
10	06-82-7276	6-19 x 1.00 Slotted Plastite T-15 Screw	(2)
★ 13	12-20-0718	Service Nameplate Kit	(1)
★ 14	28-14-0997	Gearcase	(1)
15	16-01-2121	Service Armature	(1)
16	18-01-2120	Service Field	(1)
17	22-20-0860	Brush Tube	(2)
18	22-32-0400	Brush Spring Clip	(2)
19	22-56-0975	Connector Block Assembly	(1)
21	28-28-0719	Diaphragm	(1)
22	31-05-0719	Baffle	(1)
23	-----	Connector Block Cover	(1)
24	31-15-0511	Spring Cover	(1)
25	31-44-0718	Right Handle Half	(1)
26	31-44-0719	Left Handle Half	(1)
27	31-50-0019	Motor Housing	(1)
28	31-52-0090	Shoe Release Lever	(1)
29	34-60-0920	External Retaining Ring	(1)
30	34-60-3680	Retaining Ring	(1)
31	40-50-0161	Torsion Spring	(1)
32	40-50-8840	Brush Spring	(2)
33	42-24-0620	Rear Spindle Bearing	(1)
34	42-50-0076	Front Cam	(1)
35	42-50-0077	Rear Cam	(1)
36	44-60-0626	Lock Pin	(1)
37	44-60-1635	Shoe Pin	(1)
38	44-66-0880	Shoe Retainer	(1)
39	45-12-0999	Gearcase Insulator	(1)
40	45-16-0645	Shoe Assembly	(1)
41	45-22-0081	Sleeve	(1)
42	45-24-0719	Lock Off Lever	(1)
43	45-88-1555	Washer	(1)
44	40-50-8850	Disc Spring	(1)
45	42-12-0155	Wobble Shaft Axel	(1)
46	32-40-0719	Intermediate Gear	(1)
47	43-06-0685	Metal Plate	(1)
48	43-06-0676	Bronz Plate	(1)
49	43-78-0525	Drive Hub	(1)
★ 50	36-92-0501	Wobble Shaft	(1)

FIG.	PART NO.	DESCRIPTION OF PART	NO. REQ.
★ 52	02-04-1510	Ball Bearing	(1)
★ 53	14-67-0135	Wobble Plate Assembly	(1)
54	34-60-1315	Retaining Ring	(1)
★ 55	06-82-7253	8-32 x 3/8" Pan Hd. Slit. Taptite T-20	(3)
56	44-86-0055	Bearing Retainer	(1)
57	45-36-1445	Spacer	(1)
58	06-55-3790	5/16-24 Spinlok Hex Nut	(1)
59	38-50-0680	Reciprocating Spindle	(1)
★ 60	-----	Front Spindle Bearing	(1)
★ 61	-----	Felt Seal	(2)
★ 62	-----	Washer	(2)
63	42-52-0380	Bearing Cap	(1)
64	14-46-1011	Steel Quik-Lok Blade Clamp Kit	(1)
65	23-66-1719	Switch Assembly	(1)
66	22-18-1719	Carbon Brush Assembly - Black	(1)
67	22-18-0719	Carbon Brush Assembly - Red	(1)
68	23-94-0016	Leadwire Assembly - Black	(1)
69	23-94-0015	Leadwire Assembly - Red	(1)
★ 70	14-08-0074	Gear Protecting Clutch Assembly	(1)

NOTES:

Press rear spindle bearing (33) flush to -.030 from front exterior face in diaphragm boss (21).

Torque spinlok hex nut (58) to 180 in./lbs. to 210 in./ lbs.

Needle bearing (3) is to be pressed from the open end flush to -.015 to face of bearing boss of diaphragm (21).

Remove brush tubes (17) prior to removing armature assembly (15) from motor housing (27).

Install brush tubes (17) into motor housing (27) only after armature assembly (15) has been secured into motor housing (27).

MILWAUKEE ELECTRIC TOOL CORPORATION
13135 W. LISBON RD., BROOKFIELD, WI 53005

REMOVING THE STEEL QUIK-LOK® BLADE CLAMP

- Remove external retaining ring (30) and pull front cam (34) off.
- Pull lock pin (36) out and remove remainder of parts and discard.

REASSEMBLY OF THE STEEL QUIK-LOK® BLADE CLAMP

- Coat new lock pin with powdered graphite.
- Hold tool in a vertical position.
- Place spring cover (24) onto spindle.
- Slide torsion spring (31) onto spindle with spring leg on hole side of spindle.
- Slide sleeve (41) onto spindle aligning hole on sleeve with hole in spindle.
- Slide rear cam (35) over sleeve until it bottoms on sleeve shoulder, ensure spring leg inserts into hole in rear cam.
- Rotate rear cam in the direction of the arrows located on spring cover until there is clearance for lock pin (36) to be inserted into sleeve/spindle holes. Insert lock pin.
- Align front cam (34) inner ribs with rear cam outer slots and slide front cam onto sleeve until it bottoms. Retaining ring (30) groove should be completely visible.
- Attach retaining ring by separating coils and inserting end of ring into groove, then wind remainder of ring into groove. Ensure ring is seated in groove.
- Blade clamp should rotate freely. During normal usage, debris may not allow blade clamp to rotate freely. The use of spray lubricant can help free blade clamp. In extreme conditions, follow these instructions to remove, clean and reassemble blade clamp.

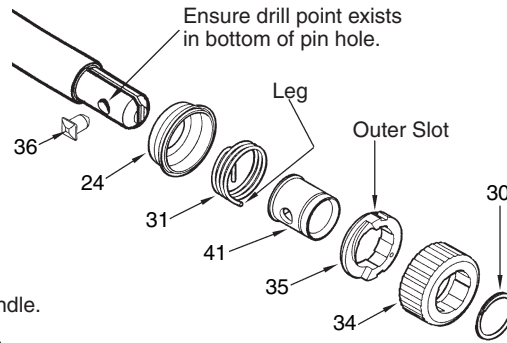

WIRING INSTRUCTIONS

Route carbon brush wires #1 and #2 into wire traps, as shown.

Carbon brush wires #1 and #2 are to be positioned with the wire crimps in the traps.

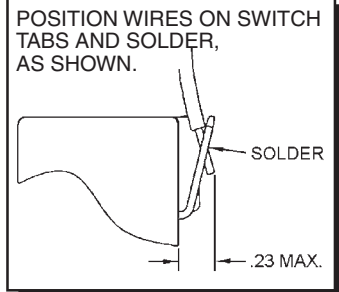

⚠ WARNING

SWITCH POLARITY SENSITIVE
If wired incorrectly, switch **will be** damaged and destroyed!

Place a heavy coat of Type "X" contact grease, No. 49-08-5000, in/on terminals of wires #3 and #4 after installing into connector block but prior to snapping on the connector block cover.

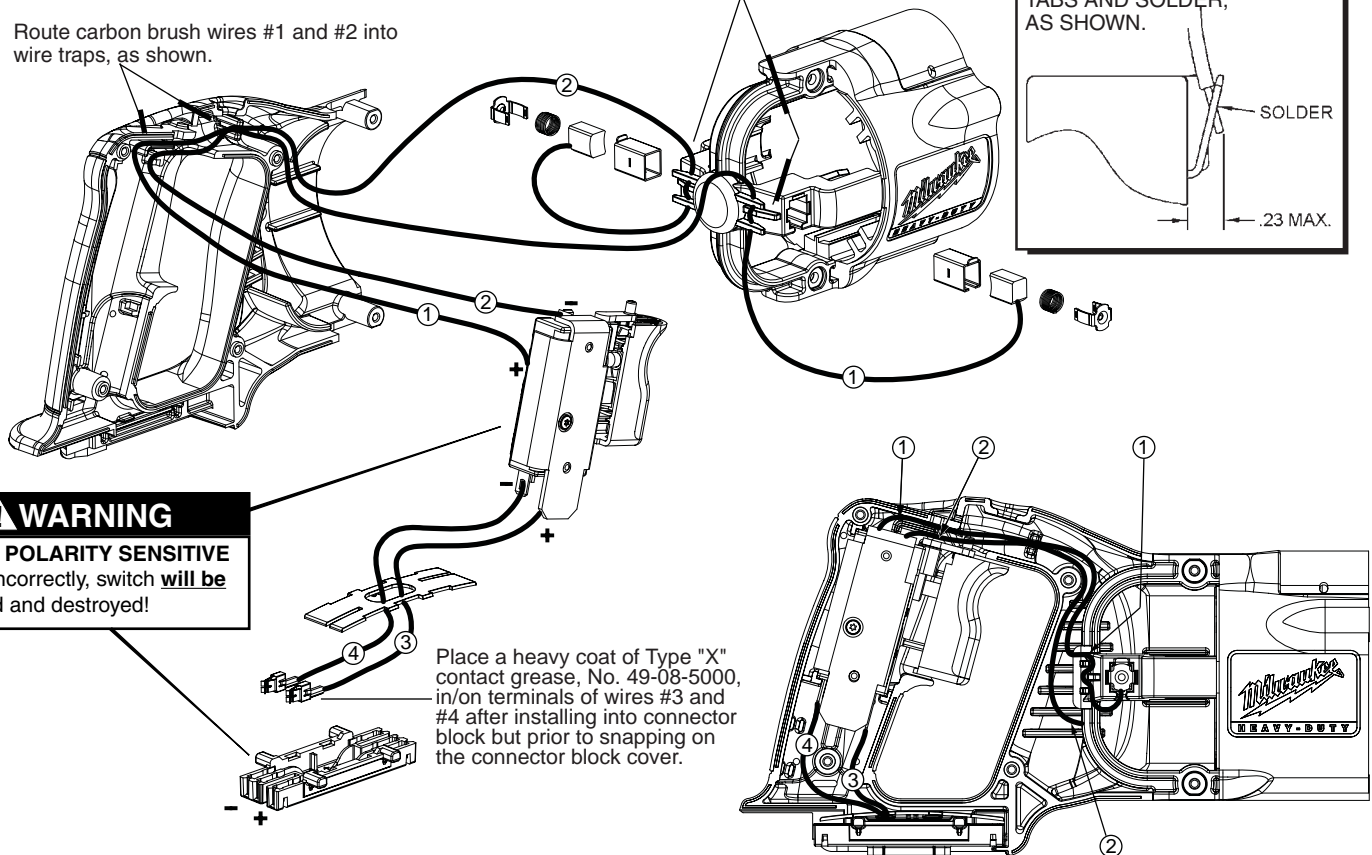

WIRING SPECIFICATIONS

Wire No.	Wire Color	Origin or Gauge	Length	Terminals, Connectors and 1 or 2 End Wire Preparation
1	Red	22-18-0719	-----	Carbon brush assembly.
2	Black	22-18-1719	-----	Carbon brush assembly.
3	Red	23-94-0015	-----	Leadwire assembly.
4	Black	23-94-0016	-----	Leadwire assembly.

TERMINAL DESCRIPTION

Code	Part No.	Qty.